

CITY OF MAYWOOD WATER QUALITY ASSESSMENT

CITY OF MAYWOOD LOS ANGELES COUNTY, CALIFORNIA



(versión en español)

Prepared for:

Maywood Mutual Water Company #1

Maywood Mutual Water Company #2

Maywood Mutual Water Company #3

Prepared by



**17885 Von Karman Avenue, Suite 500
Irvine, California 92614
(949) 809-5000**

December 15, 2010

CITY OF MAYWOOD WATER QUALITY ASSESSMENT

**CITY OF MAYWOOD
LOS ANGELES COUNTY, CALIFORNIA**

Prepared for:

Maywood Mutual Water Company #1

Maywood Mutual Water Company #2

Maywood Mutual Water Company #3

December 15, 2010

Prepared by:



GeoTrans, Inc., A Tetra Tech Company
17885 Von Karman Avenue, Suite 500
Irvine, California 92614

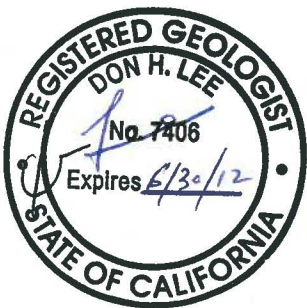

A handwritten signature in blue ink, appearing to read "Don Lee".

Don Lee, PG, C.HG.
Senior Hydrogeologist

A handwritten signature in blue ink, appearing to read "Steve Tedesco".

Steve Tedesco, P.E.
Senior Vice President (Tt EAS)

ÍNDICE

1.0	INTRODUCCIÓN	ERROR! BOOKMARK NOT DEFINED.2
1.1	PROPÓSITO DEL ESTUDIO	ERROR! BOOKMARK NOT DEFINED.2
2.0	FUENTES DE AGUA DE LA CIUDAD DE MAYWOOD	4
2.1	FUENTES DE AGUA DE LA CIUDAD	ERROR! BOOKMARK NOT DEFINED.4
2.2	NIVELES DE MANGANESO	4
2.3	CONTRIBUCIONES DE MANGANESO POR FUENTE	5
2.4	COMUNIDADES ALEDAÑAS	6
3.0	OPCIONES PARA LA MEJORA DE LA CALIDAD DEL AGUA	ERROR! BOOKMARK NOT DEFINED.7
3.1	MAYWOOD MUTUAL WATER COMPANY #1	7
3.1.1	Medidas a corto plazo	Error! Bookmark not defined.7
3.1.2	Propuestas a largo plazo	7
3.2	MAYWOOD MUTUAL WATER COMPANY #2	8
3.2.1	Medidas a corto plazo	Error! Bookmark not defined.8
3.2.2	Propuestas a largo plazo	Error! Bookmark not defined.8
3.3	MAYWOOD MUTUAL WATER COMPANY #3	8
3.3.1	Medidas a corto plazo	Error! Bookmark not defined.9
3.3.2	Propuestas a largo plazo	9
3.3.3	Perclorato	9
4.0	TECNOLOGÍA PARA REMOVER MANGANESO Y TCE	10
4.1	REMOCIÓN DE MANGANESO	10
4.2	REMOCIÓN DE TCE	10
5.0	FUENTES POTENCIALES DE FINANCIAMIENTO	ERROR! BOOKMARK NOT DEFINED.13

TABLAS

Tabla 1	Fuentes y cantidad aproximada de agua servida a la ciudad de Maywood en 2009
Tabla 2	Niveles promedio de manganeso en las fuentes de agua de Maywood en 2009
Tabla 3	Contribución de manganeso de las fuentes de agua de Maywood en 2009
Tabla 4	Niveles de TCE en las fuentes de agua de Maywood Mutual Water Company #3 en 2009
Tabla 5	Fuentes potenciales de financiamiento

FIGURA

Figura 1	Área de estudio
----------	-----------------

ANEXOS

Anexo A	Información acerca del sistema de agua
Anexo B	Concentraciones de manganeso, TCE y perclorato
Anexo C	Concentraciones de manganeso y TCE en el suministro de agua pública en comunidades dentro de un radio de 20 millas de la ciudad de Maywood
Anexo D	Contenedores de reacción para oxidación química y esquemas de filtros de presión

1.0 INTRODUCCIÓN

Este informe presenta los resultados del estudio sobre la calidad del agua potable de la ciudad de Maywood llevado a cabo por GeoTrans Inc., una compañía de Tetra Tech, a petición de Maywood Mutual Water Company #1, Maywood Mutual Water Company #2 y Maywood Mutual Water Company #3 (las mutuales Maywood), los tres sistemas de agua pública que sirven a la ciudad de Maywood en el condado de Los Angeles, California.

El 11 de octubre de 2009, la Asamblea de California aprobó un proyecto de ley, Proyecto de Ley de la Asamblea N° 890 (AB 890), solicitando que los sistemas de agua pública que sirven a la ciudad de Maywood llevaran a cabo un estudio sobre el suministro de agua de la ciudad y abordaran los impactos del manganeso. Hasta ahora no se ha encontrado que los sistemas de agua pública que sirven a la ciudad de Maywood excedan las pautas primarias federales y estatales para agua potable y, por lo tanto, no están violando sus permisos. Sin embargo, un número de pozos de agua de Maywood tienen concentraciones de manganeso que están por encima del Nivel Secundario Máximo de Contaminante (*Secondary Maximum Contaminant Level, SMCL*) de 50 microgramos por litro (ug/L o partes por billón). Las concentraciones de manganeso mayores de este nivel son indeseables porque causan una apariencia oxidada, mal sabor y decoloración de la plomería y ropa. Los problemas con el manganeso han afectado la aceptación de los recursos hídricos por parte de los clientes. El objetivo de la AB 890 es determinar hasta dónde llega el impacto del manganeso en el agua potable de la ciudad de Maywood y las posibles acciones necesarias para resolver la situación. La AB 890 especifica que debe llevarse a cabo un estudio para identificar las fuentes de manganeso y las mejoras inmediatas y a largo plazo de la infraestructura que pueden considerarse para reducir los niveles de manganeso y otros contaminantes para llevar el agua a los mismos patrones que las zonas aledañas. La AB 890 también especifica información acerca de las fuentes de financiamiento que pueden buscar los sistemas de agua pública para costear dichas mejoras.

1.1 PROPÓSITO DEL ESTUDIO

El propósito de este estudio es llevar a cabo una revisión de la información disponible, identificar el posible origen del manganeso, evaluar cuánto afecta el mismo el suministro de agua potable pública de la ciudad de Maywood y presentar potenciales acciones que los sistemas de agua pública puedan considerar para mitigar las preocupaciones acerca de la calidad del agua. Los objetivos del estudio, tal como lo establece la AB 890, son obtener lo siguiente:

- Información sobre pruebas y resultados de manganeso de las fuentes de agua potable de la ciudad de Maywood;
- La cantidad de manganeso que contribuye cada fuente de agua que sirve a la ciudad;
- Los pasos inmediatos y a largo plazo que los sistemas de agua pública pueden tomar para reducir la cantidad de manganeso en el suministro de agua potable para estar por lo menos tan bajo como un nivel consistente con el nivel promedio de las comunidades dentro de un radio de 20 millas de la ciudad de Maywood;
- Mejoras que puedan hacerse a la infraestructura para lograr los objetivos inmediatos y a largo plazo para reducir el nivel de manganeso y otros contaminantes en el agua para ser

consistente con el nivel promedio en las comunidades dentro de un radio de 20 millas de la ciudad de Maywood, y

- Acciones que los sistemas de agua pública puedan tomar para lograr financiamiento para alcanzar esas mejoras.

Este informe presenta un resumen de los hallazgos del estudio y posibles acciones que las mutuales Maywood pueden considerar para mejorar la calidad del agua.



Figura 1. Área de estudio

2.0 FUENTES DE AGUA DE LA CIUDAD DE MAYWOOD

Las fuentes de agua de la ciudad de Maywood, la cantidad de agua suministrada y la contribución de manganeso en 2009 están resumidas en esta sección.

2.1 FUENTES DE AGUA DE LA CIUDAD

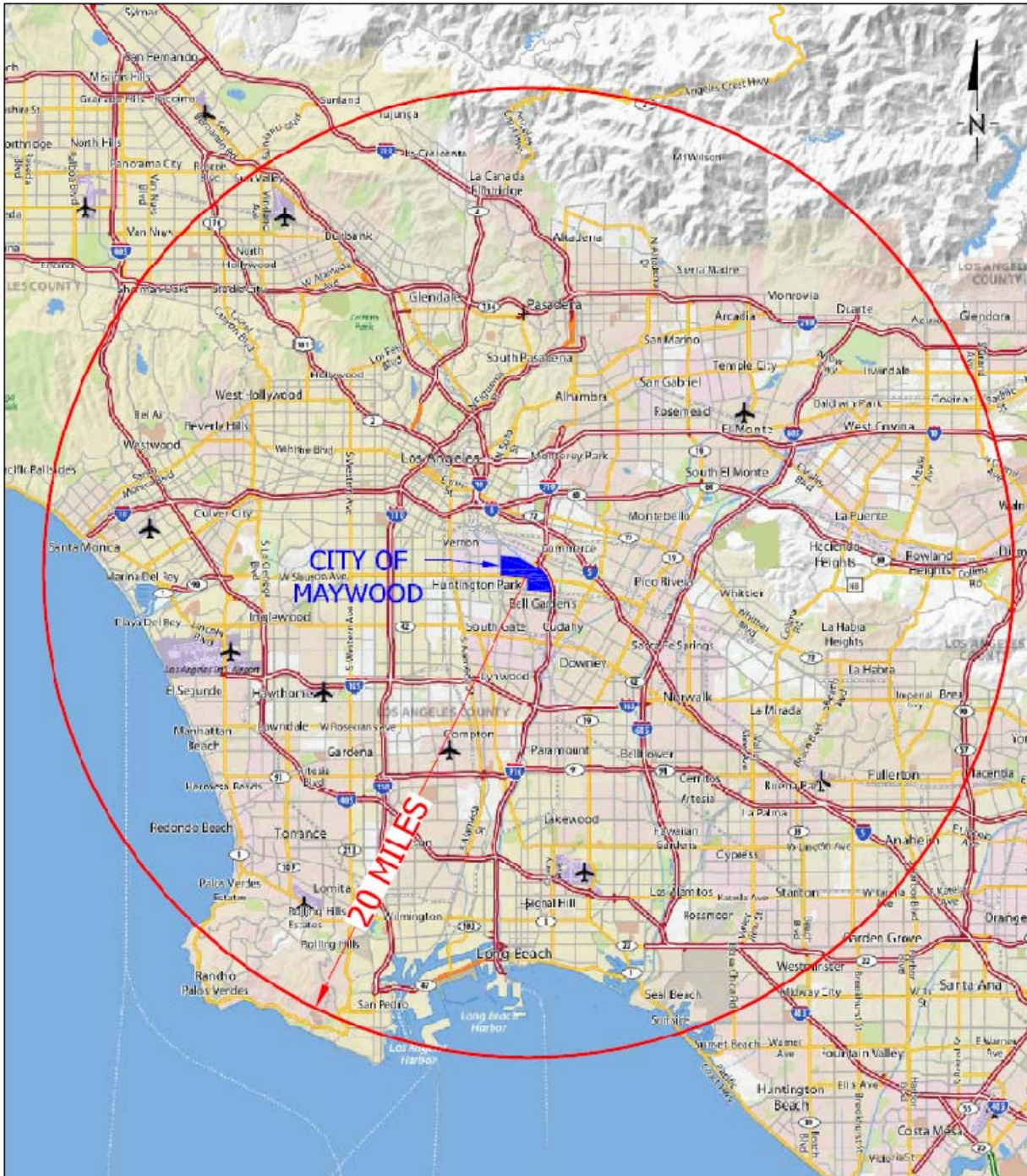
Fuente		Cantidad de agua servida a la ciudad de Maywood (Acre-pies)	%
Maywood Mutual Water Co. #1*	Pozo #3	91	4
	Pozo #4	136	6
	CBMWD (agua importada)	12	1
Maywood Mutual Water Co. #2	Pozo de la ave. Maywood (Pozo #1)	747	35
	Pozo de la calle 52 (Pozo #2)	397	18
	CBMWD (agua importada)	0	0
Maywood Mutual Water Co. #3	Pozo <i>Prospect</i> (Pozo #1)	371	17
	Pozo <i>Warehouse</i> (Pozo #7)	228	11
	Pozo distrital (Pozo #4)	173	8
Total		2155	100

Tabla 1. Fuentes y cantidad aproximada de agua servida a la ciudad de Maywood en 2009 (enero a diciembre de 2009).

Fuente de información: las mutuales Maywood

* Periodo julio 2009 a junio 2010 para Maywood Mutual Water Co. #1.

CBMWD – Distrito de Agua Municipal Central Basin; agua superficial importada.

Maywood Mutual Water Company #1 produjo un total de aproximadamente 795 acre-pies de agua durante el año fiscal 2009 (julio 2009 a junio 2010), de los cuales aproximadamente 30% (239 acre-pies) fueron servidos a la ciudad de Maywood, según Maywood Mutual Water Company #1.

Maywood Mutual Water Company #2 produjo un total de aproximadamente 1.179 acre-pies de agua en 2009, de los cuales aproximadamente 97% (1.144 acre-pies) fueron servidos a la ciudad de Maywood, según Maywood Mutual Water Company #2.

Maywood Mutual Water Company #3 produjo un total de aproximadamente 1.502 acre-pies de agua en 2009, de los cuales aproximadamente 52% (772 acre-pies) fueron servidos a clientes en la ciudad de Maywood, según Maywood Mutual Water Company #3.

En el Anexo A se provee una descripción del sistema de agua actual de las tres mutuales Maywood, incluyendo una copia de los reportes de confianza de los consumidores de 2009 (*Consumer Confidence Reports, CCR*).

2.2 NIVELES DE MANGANESO

En 2009, el *Water Replenishment District of Southern California* (Distrito de Reabastecimiento de Agua del Sur de California, WRD por sus siglas en inglés) recolectó muestras de agua de los pozos de suministro mensual y trimestralmente, según los requisitos de muestreo de la Sección 22. Las mutuales Maywood están llevando a cabo muestreos de agua y pruebas de manganeso adicionales. Las muestras de agua recolectadas se obtuvieron directamente de la descarga del

pozo antes de cualquier tratamiento. Las muestras de agua recolectadas son analizadas para ver si contienen manganeso bien sea mediante el método 200.7 o 200.8 de EPA en laboratorios certificados por el estado de California. Los resultados de manganeso de la base de datos del *California Department of Public Health* (Departamento de Salud Pública de California, CDP por sus siglas en inglés) están incluidos en el Anexo B y están resumidos abajo.

	Fuente de agua	Número de muestras	Concentración de Manganeso (ug/L)	
			Promedio	Rango
Maywood Mutual Water Co.#1	Pozo #3	21	13.9	ND(20) – 70
	Pozo #4	17	82.2	69 - 110
	CBMWD (agua importada)	NA	ND(20)	ND(20)
Maywood Mutual Water Co.#2	Pozo de la ave. Maywood (#1)	63	61.7	51 - 93
	Pozo de la calle 52 (#2)	64	73.3	45 - 150
	CBMWD (agua importada)	0	-	-
Maywood Mutual Water Co.#3	Pozo <i>Prospect</i>	1	ND(20)*	ND(20)*
	Pozo <i>Warehouse</i>	1	ND(20)*	ND(20)*
	Pozo distrital	1	26*	26*

Tabla 2. Niveles promedio de manganeso en las fuentes de agua de Maywood en 2009.

Fuente de información: base de datos de la calidad del agua de CDPH. La información sobre manganeso para el agua de CBMWD fue obtenida del CCR de 2009 de Maywood Mutual Water Co.#1.

ND(20) - No se detectó mayor al umbral de notificación indicado.

*Resultados de las muestras del 24/4/2008. No se tomaron muestras en 2009.

La concentración promedio de manganeso mayor al SMCL de 50 ug/L fue identificada en tres pozos (Pozo #4 en 82,2 ug/L, pozo de la avenida Maywood en 61,7 ug/L y pozo de la calle 52 en 73,3 ug/L).

2.3 CONTRIBUCIÓN DE MANGANESO POR FUENTE

La cantidad de manganeso que contribuyó cada fuente de agua de la ciudad de Maywood en 2009 se estimó utilizando la información sobre producción de agua y la concentración de manganeso. Los resultados se muestran abajo.

	Fuente	Cantidad de agua servida a la ciudad de Maywood (Acre-pies)	Concentración promedio de manganeso (ug/L)	Cantidad de manganeso que contribuyó cada fuente	
				(lbs/día)	(%)
Maywood Mutual Water Co.#1	Pozo #3	91	13.9	0.01	1
	Pozo #4	136	82.2	0.08	11
	CBMWD (agua importada)	12	ND(20)	<0.01	<1
Maywood Mutual Water Co.#2	Pozo de la ave. Maywood	747	61.7	0.34	45
	Pozo de la calle 52	397	73.3	0.22	29
	CBMWD (agua importada)	0	-	0	0
Maywood Mutual Water Co.#3	Pozo <i>Prospect</i>	371	ND(20)*	0.03	4
	Pozo <i>Warehouse</i>	228	ND(20)*	0.02	3
	Pozo distrital	173	26*	0.05	7
Total		2155	-	0.75	100

Tabla 3. Contribución de manganeso de las fuentes de agua de Maywood en 2009.

Fuente de información: base de datos de la calidad del agua de CDPH. La información sobre manganeso para el agua de CBMWD se obtuvo del CCR de 2009 de Maywood Mutual Water Co.#1. La información sobre la producción fue provista por las mutuales. ND(20) –No se detectó mayor al umbral de notificación indicado.

**Resultados de la muestra del 24/4/2008. No se tomaron muestras en 2009.*

Para propósitos de cálculo, se utilizó un valor estimado de 10 ug/L, un medio del umbral de notificación del laboratorio, para resultados no detectados.

En 2009, aproximadamente 74% de la masa total de manganeso se originó en dos pozos (45% en el pozo de la avenida Maywood y 29% en el pozo de la calle 52); la contribución de las otras fuentes de agua fue significativamente menor. En 2009, la contribución de manganeso por proveedores de agua, Maywood Mutual Water Company #1, Maywood Mutual Water Company #2 y Maywood Mutual Water Company #3 fue de aproximadamente 12%, 74% y 14%, respectivamente.

2.4 COMUNIDADES ALEDAÑAS

Se revisó la información sobre manganeso publicada en los CCR de 2009 para las comunidades ubicadas dentro de un radio de 20 millas de la ciudad de Maywood para determinar los niveles de manganeso en su agua potable.

En base a la información disponible de un total de 113 proveedores de agua en 2009, la concentración promedio de manganeso en las comunidades dentro de un radio de 20 millas de Maywood (sin incluir las mutuales Maywood) es de 13.7 µg/L (lo que es menor al umbral de notificación de manganeso de 20 µg/L). El manganeso fue notificado como no detectado en el umbral de notificación de 20 µg/L en aproximadamente 88% de los CCR. En el Anexo C se incluye un resumen de la información sobre manganeso para las comunidades aledañas.

3.0 OPCIONES PARA LA MEJORA DE LA CALIDAD DEL AGUA

En esta sección se presenta una descripción de las opciones que las mutuales Maywood podrían considerar para reducir la cantidad de manganeso en el suministro de agua potable. El objetivo es que la concentración de manganeso sea por lo menos tan baja como un nivel consistente con la concentración promedio en las comunidades dentro de un radio de 20 millas de la ciudad de Maywood (es decir 13,7 µg/L o menor que el límite de detección de 20 µg/L).

3.1 MAYWOOD MUTUAL WATER COMPANY #1

El pozo #4 del sistema de Maywood Mutual Water Company #1 tiene niveles de manganeso superiores al SMCL. Los restantes Pozo #3 y las fuentes de agua superficial importada del *Central Basin Municipal Water District* (Distrito de Aguas Municipales de Central Basin, CBMWD por sus siglas en inglés) tienen niveles de manganeso más bajos.

3.1.1 Medidas a corto plazo

Una medida a corto plazo es limitar el uso del Pozo #4 y mezclar el agua del Pozo #4 con la del Pozo #3 y/o el agua de CBMWD. Maywood Mutual Water Company #1 ha entregado para aprobación un Plan de Mezcla (Anexo A) al CDPH para mezclar 80% (40 µg/L) del SMCL de manganeso y ha estado mezclando el agua de los Pozos #3 y #4 desde otoño de 2009. La concentración de manganeso en el agua mezclada oscila entre menos del límite de detección de 20 µg/L y 40 µg/L (Anexo A) en la tubería de distribución dentro de la ciudad de Maywood. Para cumplir con los requisitos de la AB 890 (13.7 µg/L o menos que los umbrales de notificación del laboratorio de 20 µg/L) se requerirá mezcla adicional a un costo mayor. Sin embargo, las instalaciones existentes son adecuadas para cumplir con los requisitos de mezcla.

3.1.2 Propuestas a largo plazo

Las propuestas a largo plazo para el sistema incluyen las siguientes:

- Modificar los pozos existentes o instalar pozos nuevos para producir desde acuíferos o unidades contenedoras de agua que tengan bajos niveles de manganeso y/o
- Hacerles un tratamientos a las fuentes de agua existentes.

En 2010 el WRD comenzó un análisis del Pozo #4 para determinar si hay acuíferos con bajas concentraciones de manganeso y si las zonas que tienen concentraciones altas pueden clausurarse. El WRD está revisando los resultados del análisis del pozo para tomar otras acciones. Alternativamente, instalar un pozo de reemplazo completado en acuíferos con bajas concentraciones de manganeso, si es factible. Esta opción requiere más investigación.

La otra propuesta a largo plazo es instalar una planta de remoción de manganeso para tratar el agua del Pozo #4. Maywood Mutual Water Company #1 ha solicitado diversos subsidios incluyendo al Fondo Rotatorio Estatal para el Agua Potable Sana (*Safe Drinking Water State Revolving Fund*) por un monto de \$2,4 millones para construir una planta de tratamiento en el Pozo #4, además de un embalse de almacenamiento nuevo. Según el CDPH, este proyecto se encuentra en la lista de Proyectos Financiados de 2010-2011 y podría recibir un acuerdo de financiamiento para el 30 de junio de 2011. Los niveles de manganeso en el Pozo #4 pueden reducirse a menos de lo requerido por la AB 890 con la tecnología de tratamiento disponible tal como oxidación seguida de filtración.

3.2 MAYWOOD MUTUAL WATER COMPANY #2

El pozo de la avenida Maywood (61.7 µg/L) y el pozo de la calle 52 (73.3 µg/L) del sistema de Maywood Mutual Water Company #2 tienen niveles de manganeso superiores al SMCL. La fuente de CBMWD tiene niveles de manganeso inferiores y está disponible pero no fue utilizada en 2009.

Maywood Mutual Water Company #2 está completando la construcción y las pruebas de un sistema de remoción de manganeso en la localidad de la calle 52. Una vez que el sistema esté probado y obtenga los permisos, el manganeso de este pozo estará por debajo de los niveles de la AB 890. La capacidad de la planta de tratamiento es de 1.100 gpm.

3.2.1 Medida a corto plazo

El plan a corto plazo es operar la planta de tratamiento de la calle 52. El agua del pozo de la avenida Maywood está disponible para mezclarse con el agua tratada de la calle 52 para producir agua 80% por debajo del SMCL para manganeso, de ser necesario. Para cumplir con los requisitos de la AB 890, se necesitará significativamente más mezcla con un gasto operativo adicional.

3.2.2 Propuestas a largo plazo

La solución a largo plazo para este problema es canalizar el agua del pozo de la avenida Maywood a la localidad de la calle 52 para ser tratada, si es factible. Sería necesaria una tubería dedicada de aproximadamente 6.000 pies lineales con tubos de 10 pulgadas; también será necesario incrementar la capacidad de la planta existente. El costo estimado de estas mejoras, estaría en el orden de \$1 a 1,5 millones. Alternativamente, investigar si el pozo de la avenida Maywood puede modificarse o si se puede instalar un pozo de reemplazo nuevo para producir desde acuíferos que tengan bajos niveles de manganeso, si es apropiado.

3.3 MAYWOOD MUTUAL WATER COMPANY #3

Los niveles de manganeso en los pozos de Maywood Mutual Water Company #3 están por debajo de las pautas de la AB 890.

Además de manganeso, se revisó la información disponible sobre la calidad del agua para determinar si en las fuentes de agua de la ciudad de Maywood había “otros contaminantes” que causaran preocupación. La AB 890 indicó que “otros contaminantes,” de estar presentes, deben ser abordados en el estudio de la calidad del agua.

La información analítica del tricloroetano (TCE) de la base de datos de la CDPH está incluida en el Anexo A y resumida abajo.

	Fuente de agua	Número de muestras	Concentración de TCE (ug/L)	
			Promedio	Rango
Maywood Mutual Water Company #3	Pozo <i>Prospect</i> (Pozo #1)	4	2,7	1,8-4,5
	Pozo <i>distrital</i> (Pozo #4)	1	ND(0,5)	ND(0,5)
	Pozo <i>Warehouse</i> (Pozo #7)	4	3,5	2,8-4,2

Tabla 4. Niveles de TCE en las fuentes de agua de Maywood Mutual Water Company #3 en 2009. Las muestras fueron tomadas de los pozos trimestralmente por WRD en 2009 y el TCE fue analizado mediante el método 524.2 de EPA en laboratorios certificados por el estado de California.

Se encontró que los niveles de tricloroetano (TCE) en el Pozo *Prospect* y en el Pozo *Warehouse* eran tan altos como aproximadamente 80% a 90% del Nivel Primario Máximo de Contaminante (Primary MCL, por sus siglas en inglés) de 5 µg/L en 2009. La producción de agua del Pozo *Prospect* se bajó de 48,1% del total del sistema en 2009 a 19,6% en 2010 debido a preocupaciones con el TCE.

Además, se revisó la información sobre TCE de comunidades ubicadas dentro de un radio de 20 millas de la ciudad de Maywood para determinar los niveles de TCE en su agua potable. En base a la información de un total de 113 proveedores de agua en 2009, la concentración promedio de TCE para un área dentro de un radio de 20 millas es 0,47 µg/L (lo cual está por debajo del umbral de notificación de laboratorio para TCE de 0,5 µg/L). El TCE se notificó como no detectado o por debajo del umbral de notificación de 0,5 µg/L en aproximadamente 85% de los CCR. En el Anexo C se incluye un resumen de la información de manganeso para las comunidades aledañas.

3.3.1 Medida a corto plazo

En un plazo corto, la Maywood Mutual Water Company #3 ha reducido su uso del Pozo *Prospect* y está mezclando esta agua con otras fuentes. Esta opción puede reducir la concentración de TCE a cerca del 80% (4,0 µg/L) del MCL, pero no al nivel de la AB 890 (0,47 µg/L o menos del umbral de notificación de laboratorio de TCE de 0,5 µg/L).

3.3.2 Propuestas a largo plazo

Las propuestas a largo plazo para el problema deben investigarse. Incluyen lo siguiente:

- Modificar los pozos existentes mediante la clausura de secciones que están produciendo TCE, si es apropiado. El costo estimado para las modificaciones del pozo estaría en el orden de los \$250.000;
- Instalar una planta de remoción de TCE en el Pozo *Prospect* o en el Pozo *Warehouse*. El costo estimado para construir una planta de tratamiento estaría en el orden de \$1 millón y/o
- Instalar pozos nuevos para producir desde acuíferos o unidades contenedoras de agua que no produzcan TCE. El costo estimado para pozos nuevos estaría en el orden de \$1,5 millones.

3.3.3 Perclorato

Se detectó perclorato en una concentración de 4,1 µg/L en una muestra de agua del Pozo *Warehouse* el 11/2/2009; sin embargo, no se ha detectado perclorato desde entonces. El nivel de perclorato está por debajo del Nivel Primario Máximo de Contaminante de 6,0 ug/L. No se detectó perclorato en los otros dos pozos de Maywood Mutual Water Company #3 . En el Anexo B se incluye una tabla resumen con información analítica sobre perclorato.

4.0 TECNOLOGÍA PARA REMOVER MANGANESO Y TCE

4.1 REMOCIÓN DE MANGANESO

El manganeso puede estar presente en el agua en una de tres formas: disuelto, en partículas y coloidal. La predominancia de una forma sobre las demás depende del pH de la fuente de agua. Los métodos de tratamiento más comunes para remover el manganeso incluyen:

- Oxidación química y filtración de presión y
- Adsorción en resinas de intercambio iónico.

La oxidación implica la adición de un agente oxidante al agua que reacciona químicamente con el manganeso para formar un precipitado y partículas insolubles. Luego, estas partículas pueden filtrarse físicamente mediante medios de presión. La oxidación puede lograrse a través de uno de los siguientes métodos:

- Aeración – soplar/rociar aire a través del agua y
- Adición de oxidantes químicos: hipoclorito de sodio, dióxido de cloro, permanganato de potasio u ozono.

Los precipitados de manganeso oxidado pueden entonces eliminarse con filtración de arena, filtración de glauconita o filtración de carbón activado.

El uso de resinas de intercambio iónico para la remoción de manganeso también se ha utilizado en aplicaciones más limitadas debido al requerimiento de que los contaminantes estén en forma disuelta y a niveles muy bajos. Esto se debe a la tendencia del oxígeno a reaccionar con el hierro y el manganeso y, por lo tanto, aumentar el potencial para bloqueo y acumulación en la superficie de la resina. Las incrustaciones de hierro son un problema común y, a veces, irreversible con el tratamiento de intercambio iónico.

Como resultado, los procesos de tratamiento más fáciles y comunes para la remoción de hierro y manganeso para aguas subterráneas es la oxidación química seguida de filtración. Para pozos típicos, las instalaciones de tratamiento consistirían de un equipo de bombeo para el suministro de químicos y tanques de almacenamiento para cloruro férrico hipoclorito de sodio como agentes oxidantes, contenedores de reacción, contenedores de filtración de presión e instalaciones de contra flujo. En el Anexo D se provee un ejemplo de los contenedores de reacción y los esquemas de filtro de presión de un suplidor de equipos, Filtronics.

4.2 REMOCIÓN DE TCE

El tricloroetano, comúnmente conocido como TCE es un hidrocarburo clorinado volátil, ampliamente utilizado como solvente removedor de pintura y agente desengrasante. Los patrones de contaminación del agua potable con TCE son generalmente similares a los patrones de uso, donde los niveles más altos y los números más altos de pozos contaminados ocurren en zonas urbanas. Más de 350 fuentes de agua potable en California tienen niveles de contaminación con TCE que deben notificarse (es decir, más de 0,5 ug/L o ppb). A aquellos sistemas con contaminación que exceda el MCL, se les requiere que provean un tratamiento que reduzca las concentraciones de TCE a niveles por debajo de 5 ug/L.

Existen diversos procesos de tratamiento de unidades utilizados comúnmente que pueden utilizarse para remover compuestos orgánicos volátiles (VOC, por sus siglas en inglés), incluyendo TCE, de las aguas subterráneas. Estos incluyen: adsorción, extracción con aire, procesos de oxidación/biológico y de osmosis inversa. Dos procesos de tratamiento, adsorción de carbón y extracción con aire, se consideran los más viables, apropiados y ampliamente aceptados para propósitos de tratamiento de agua potable. Estas dos tecnologías tienen mayor aceptación de la comunidad reguladora de agua pública y proveen una remoción eficiente y predecible de contaminantes.

La adsorción de carbón, normalmente utilizando carbón activado como el medio adsorbente, se sabe que es un proceso de tratamiento de agua efectivo para la remoción de VOC. El *proceso de adsorción* es un fenómeno de superficie física donde se extrae un adsorbato (el contaminante, en este caso) de la solución contaminada y se aferra a la superficie del adsorbente (carbón activado) por varios tipos de fuerzas químicas y físicas presentes. Los contaminantes a ser removidos son adsorbidos y aferrados a la superficie (y superficies interespaciales o poros) del sólido adsorbente hasta que éste ya no posee la capacidad de acumular ningún adsorbato adicional. El carbón activado granular (GAC, por sus siglas en inglés), específicamente adsorción de carbón en fase líquida, es lo que se usa más comúnmente como adsorbente debido a su mayor capacidad de adsorción para lograr la reducción de ciertos químicos orgánicos (orgánicos semi-volátiles y volátiles) y compuestos de cloro de las aguas contaminadas. GAC es un medio adsorbente efectivo debido a su gran área superficial en relación al volumen.

Los sistemas de extracción con aire y aeración también se utilizan ampliamente en los tratamientos de agua para la remoción de compuestos orgánicos volátiles (VOC), amoníaco (NH₃), dióxido de carbono (CO₂), sulfuro de hidrógeno (H₂S) y radón del agua potable. La base del proceso de extracción por aire es la transferencia de masa de compuestos orgánicos volátiles disueltos en el agua de la fase líquida a la fase de vapor (gas/aire). Los extractores de aire remueven los VOC del líquido (agua) proveyendo contacto entre el líquido contaminado y un gas (aire). El contaminante (en la fase de vapor) es entonces normalmente liberado a la atmósfera (o puede eliminarse mediante sistemas de tratamiento de gases de escape, usualmente unidades de adsorción de carbón en fase de vapor). Las normas de calidad del aire y los requerimientos para obtener los permisos reglamentarios indican los requisitos apropiados para la liberación o tratamiento de los gases de escape producidos por los extractores de aire.

La facilidad y la eficiencia de la transferencia de masa de los contaminantes a ser removidos (VOC) a la fase de vapor depende de la constante de la ley de Henry (*Henry's law constant*) del contaminante a ser removido. En equilibrio, la presión parcial de un gas sobre un líquido es directamente proporcional a la fracción molar del gas disuelto en el líquido. Esta proporcionalidad es conocida como la *constante de la ley de Henry* (H) y su valor es una parte importante para determinar si el contaminante es susceptible a la extracción e impacta el diseño del proceso y los parámetros operativos para los extractores de aire. La temperatura y la presencia de otros contaminantes (incluyendo componentes inorgánicos) en el agua a ser tratada afectan el valor de la constante de Henry.

Una consideración importante en el diseño del proceso para los extractores de aire es la relación entre el flujo volumétrico de aire y el flujo volumétrico de agua (A/W); a esto se le conoce como "*relación aire-agua*" (es decir pies cúbicos por minuto de aire a pies cúbicos por minuto de agua). El valor óptimo de la relación aire-agua varía para los diferentes VOC (en base a sus respectivas

constantes de Henry) así como la concentración afluente y la concentración efluente esperada o deseada después de la extracción.

Los extractores de aire transfieren los contaminantes de un medio a otro (líquido a gas) y, por lo tanto, no hay destrucción del contaminante; en consecuencia, se debe considerar el gas de escape generado por esta tecnología. Normalmente, la masa del contaminante extraído y desechado de la unidad no implica un riesgo a la salud ni requiere más tratamientos para eliminarlo de la corriente de aire. En ese caso, el gas de escape es desechado directamente a la atmósfera. Sin embargo, cada situación debe analizarse para confirmar esta condición y el cumplimiento y la coordinación apropiados con los requerimientos para obtener los permisos reglamentarios correspondientes relativos al aire. El tratamiento del gas de escape puede incorporarse si la masa eliminada es suficiente como para requerirlo. El tratamiento del gas de escape puede llevarse a cabo mediante diversos métodos, el más común es por la adsorción de carbón en fase de vapor.

Las preocupaciones operativas por los extractores de aire incluyen el tratamiento previo o la limpieza periódica de columnas requeridas debido a la presencia de otros contaminantes en el agua afluente incluyendo componentes inorgánicos (incluyendo durezas de calcio, hierro y manganeso). Los otros contaminantes que pueden producirse en el extractor si no se mantiene apropiadamente incluyen algas, hongos, bacteria o sedimentos de partículas finas. El proceso de extracción de aire también requiere de una cantidad sustancial de energía para funcionar. La energía se requiere principalmente para el equipo de aeración (sopladores) y podría necesitarse para el bombeo afluente y efluente desde la unidad, dependiendo de su ubicación en el proceso de tratamiento en general.

5.0 FUENTES POTENCIALES DE FINANCIAMIENTO

El financiamiento para proyectos de suministro de agua está disponible a través de una variedad de entidades federales, estatales y locales. La tabla 5 abajo, indica algunas de las fuentes de financiamiento disponibles actualmente.

Agencia patrocinante	Potencial programa de financiamiento
California Department of Public Health	<ul style="list-style-type: none"> Fondo Rotatorio Estatal para el Agua Potable Sana Proposición 50 <i>Protección del Agua, Agua Potable Limpia, Protección de Costas y Playas</i> Proposición 84 <i>Agua Potable Sana, Calidad y Suministro del Agua, Control de Inundaciones, Protección de Ríos y Costas</i>
California Department of Water Resources	<ul style="list-style-type: none"> Proposición 50 <i>Programa Integrado Regional de la Gerencia del Agua (posible vuelta futura)</i> Proposición 82 Nuevos Préstamos para la Construcción de Suministros Locales de Agua
State Water Resources Control Board	<ul style="list-style-type: none"> Proposición 50 <i>Programa Integrado Regional de la Gerencia del Agua (posible vuelta futura)</i> Fondo Rotatorio Estatal para el Agua Limpia
Metropolitan Water District of Southern California	<ul style="list-style-type: none"> Programa de Asociación Comunitaria
U.S. Bureau of Reclamation	<ul style="list-style-type: none"> Agua 2025: Prevención de Crisis y <i>Conflicto en el Oeste – Año fiscal 2008</i>
U.S. Army Corps of Engineers	<ul style="list-style-type: none"> Acta para el Desarrollo de los Recursos Hídricos (WRDA, por sus siglas en inglés)

Tabla 5. *Fuentes potenciales de financiamiento*

Maywood Mutual Water Company #1 y #2 ya han solicitado diversos subsidios y préstamos para la remoción de manganeso.

Maywood Mutual Water Company #3 ha solicitado y está en lista de espera para un programa de análisis de pozos financiado por WRD para determinar el origen del TCE en uno o más pozos. Maywood Mutual Water Company #3 también está en la lista de espera de WRD para una posible modificación o reemplazo de pozo, si se excede el MCL.

ANEXO A
INFORMACIÓN ACERCA DEL SISTEMA DE AGUA

ANEXO A

MAYWOOD MUTUAL WATER COMPANY #1

INFORMACIÓN ACERCA DEL SISTEMA DE AGUA

Maywood Mutual Water Company #1 sirve a aproximadamente 5.500 residentes en partes de las ciudades de Maywood y Huntington Park. Aproximadamente 795 acre-pies de agua fueron producidos por Maywood Mutual Water Company #1 en el año fiscal 2009 (julio de 2009 a junio de 2010), de los cuales aproximadamente 30% de la producción total fue servida a la ciudad de Maywood, según Maywood Mutual Water Company #1. Una zona de presión única está servida por dos pozos de agua subterránea y fuentes de agua superficial importada indicados en la siguiente tabla:

Fuente	Capacidad (gpm)	Comentarios
Pozo #3	690	Bombee directamente al sistema de distribución
Pozo #4	980	Bombee al embalse de almacenamiento y luego es impulsada al sistema de distribución
Distrito de agua municipal Central Basin (CBMWD, agua importada)	2.900	Surte directamente al sistema de distribución y al tanque de almacenamiento. Actualmente, la capacidad de esta conexión está establecida en 1.500 gpm

Maywood Mutual Water Company #1 también tiene conexiones de emergencia para la ciudad de Huntington Park y los sistemas de agua de Maywood Mutual Water Company #2. Según Maywood Mutual Water Company #1, estas conexiones no han sido utilizadas hasta ahora.

La producción de agua semanal promedio en verano (2007-2008) es la siguiente:

Fuente	Producción (MG)	Porcentaje
Pozo #3	2,33	40,24
Pozo #4	2,65	45,70
CBMWD	0,82	14,00
Totales	5,80	100%

Maywood Mutual Water Company No. 1

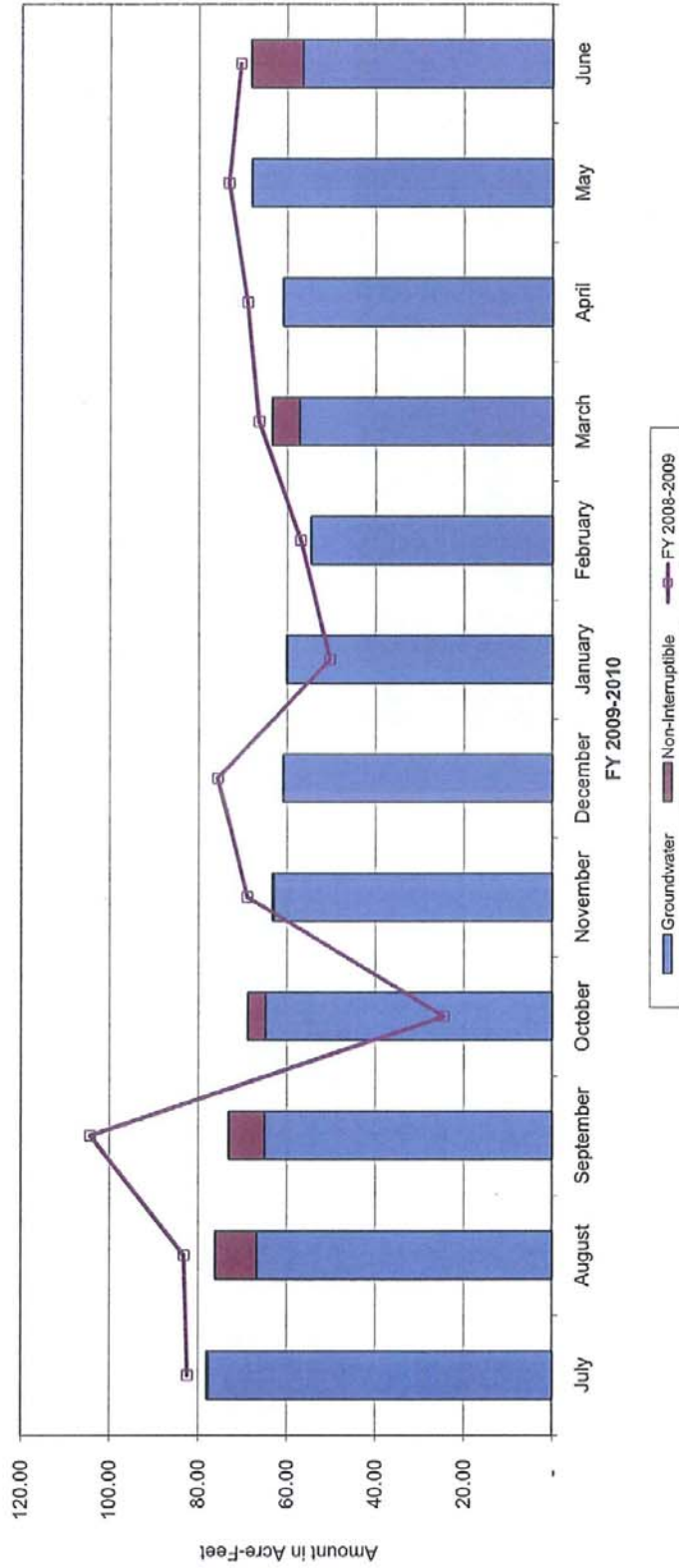

Maywood Mutual Water Company No. 1	Fiscal Year 2009-2010												TOTAL
	July	August	September	October	November	December	January	February	March	April	May	June	
Groundwater	77.57	66.71	65.02	64.79	62.94	60.73	59.97	54.55	57.16	60.86	67.92	56.43	754.65
Non-Interruptible	0.40	9.40	8.10	3.90	0.30	0.10	0.10	-	6.20	-	-	11.60	40.10
Total	77.97	76.11	73.12	68.69	63.24	60.83	60.07	54.55	63.36	60.86	67.92	68.03	794.75

Note that Seasonal Storage Long-Term (In-Lieu) water was not available during FY 2009-10

MANGANESE BLENDING PLAN

FOR

MAYWOOD MUTUAL WATER COMPANY #1

Prepared by: Sergio Palos, Chief Operator

5953 Gifford Avenue
Huntington Park, California 90255
(323) 560-2439

Maywood Mutual Water Company #1 – Manganese Blending Plan - 2009

INTRODUCTION

On April 10, 2009 Maywood Mutual Water Company #1 received a letter from California Department of Public Health (CADPH) stating that well No. 4 showed that manganese levels that consistently exceeded the secondary standard for manganese, the maximum contaminate level (MCL) is 50ug/l. CADPH is requiring that Maywood Mutual Water Company #1 either treat the water from Well #4 by removal of the excess manganese or submit a blending plan that would assure compliance of the secondary MCL rule.

Manganese / Black & Brown Staining

Manganese will cause a black stain and will many times be accompanied by iron and hydrogen sulfide gas odor. In combination with iron, manganese staining will sometimes be chocolate colored or brown. Evidence of manganese staining is usually most prominent in the dishwasher. The detergents used to wash the dishes raise the pH of the water high enough (>8) to allow the manganese to easily precipitate. A second place to see a manganese problem is on the top of the water in the toilet storage tank. The manganese will form a film that is sometimes mistaken for oil on the water. If you touch the surface of this water, the film will break into flakes with jagged edges. At high concentrations (>.2 ppm), the manganese will give the water what is sometimes described as a sweet taste.

Manganese generally exists in two forms

Manganous manganese - This form of manganese is invisible in the water just like dissolved sugar is. Just like sugar water, the manganese can not be mechanically filtered from the water.

Manganic manganese - This form has precipitated (formed a solid and is no longer in solution - it has turned to rust - "oxidized") and gives the water a cloudy black appearance. This form of manganese can be mechanically filtered. The reason for this is the waters have a pH above the 8 required to oxidize the manganous form into the manganic form.

Although manganese is generally not considered to be a health risk, a level of greater than 50 ppb is a cause for concern. The State of California does recommends that greater than 50 ppb be reduced.

The request for a blending plan is based on the lack of customer complains in regards to staining of laundry, plumbing fixtures or odor in the water.

This paper will try to give the reader a clear understanding of the working conditions of the water system at Maywood Mutual Water Co. #1; and propose solutions to the concerns of manganese from our well #4 to the California Department of Public Health (CADPH).

Maywood Mutual Water Company #1

SYSTEM NUMBER 1910084

System Hydraulics and Water Movement

General information on Maywood Mutual Water Company #1 water system # 1910084

Maywood Mutual Water Company #1 is a rectangular shape water distribution system; serving the cities of Huntington Park and Maywood. Maywood Mutual Water Company #1 serves about 5500 residence within our service area. We operate as (1) one zone only.

This paper will concentrate on the Iron and Manganese issues; and what Maywood Mutual Water Company has done to mitigate both iron and manganese within the distribution system that serve our customers.

Maywood Mutual Water Company #1 operates two groundwater wells.

- 1.) Groundwater Well #3 is located at 6026 Carmelita Avenue, Huntington Park, California 90255.
Built in 1937
- 2.) Groundwater Well #4 is located at 5953 South Gifford Avenue, Huntington Park, California 90255.
Built in 1950

Maywood Mutual Water Company #1 has (2) two emergency intersystem connection points.

- 1.) The City of Huntington Park intersystem connection located at the corner of Randolph Avenue and Maywood Avenue near the ally.
- 2.) Maywood Mutual Water Company #2 intersystem connection located near the corner of Carmelita Avenue and Slauson Avenue.

These (2) two emergency intersystem connection points have never been used yet to my knowledge.

Groundwater Well #3

Groundwater Well #3 built in 1937 produces 690 gallons per minute. This well pumps directly into the distribution system. It is designed to allow as much water to flow into our tanks as possible. The water should flow towards 60th Street which has a 10 inch water main leading to our plant storage tanks. As the distribution system pressure increases; a pressure reducing valve at the booster and storage tank station located at our 5953 Gifford Ave. will open and allow water to flow into the water tanks to relieve pressure build-up within the distribution system; and fill our tanks for the next days usage.

Groundwater Well #4

Groundwater Well #4 built in 1950 produces 980 gallons per minute. This well water is pump by the chlorinator injection point to our sand trap and then into our water reservoirs and held.

Chlorination Pump

We have (2) two 200 gallon tanks with sodium hypochlorite 12½%; which feed well water #4 that goes into our tanks. Our target residual is 1.0 mg/l average chlorine for tank storage. System demand is about 0.5 mg/l and remaining total chlorine in system averages 0.5 to 1.0 mg/l.

Well #3 has (2) 200 gallon tanks with sodium hypochlorite 12½%; which feed the system and tanks. We set a very low chlorine feed of about 0.4 mg/l.

Maywood Mutual Water Company #1 uses Pulsatron pump for delivery of the chlorine to the well water.

Maywood Mutual Water Company #1 – Manganese Blending Plan - 2009

Well Name	Well #3	Well #4
Address	6026 Carmelita Ave., Huntington Park, CA 90255	5953 Gifford Ave., Huntington Park, CA 90255
Date Drilled ...	1946	1950
Location	Residential	Residential
Lot Size ...	50 X 150	122 X 285
Distance to Sewer	53 Feet	Over 50 feet
Sewer Disposal ...	None	None
Abandon Well ...	None	None
Nearest Property Line ...	25 Feet	40 Feet
Housing Type		
Condition ...	Good	Good
Floor ...	Concrete	Concrete
Drainage ...	Good	Good
Well Depth		
Depth ...	1200 Feet	1435 Feet
Diameter ...	16 Inches	16 & 14 Inches
Casing Kind ...	8 ga. Steel	8 ga. Steel
Height Above Floor ...	30 Inches	Flush
Distance To Highest Perforations ...	506 Feet	837 Feet
Surface Sealed ...	Yes	Yes
Gravel Pack ...	No	No
Second Casing Depth ...	None	None
Second Casing Diameter ...	None	None
Annular Seal - Depth ...	None	None
Sampling Tap & Meter ...	Yes	Yes
Impervious Strata: Thickness	28' - 33' - 25'	72' - 166' - 29' - 22'
Penetrated - Depth to	162' - 322' - 455'	18' - 96' - 186' - 320'
Water Levels:		
Static ...	176	187
Pumping ...	287	263
Drawdown ...	111	76
Pump		
Make ...	Layne & Bowler	Layne & Bowler
Type ...	Vertical Turbine 125 hp	Vertical Turbine 125 hp
Capacity - GPM ...	690	980
Lubrication ...	Oil	Oil
Power ...	Electric	Electric
Auxiliary Power ...	None	Stand-By Generator
Controls ...	Auto & Manual - RTU	Auto & Manual - RTU
Discharge Location ...	Below Ground	Above Ground
Discharge To ...	Water System	To Water Reservoirs
Frequency of Use ...	Daily	Daily
Primary Station Code ...	02S / 13W - 24F01 S	02S / 13W - 24B02 S
State Well Number ...	2S / 13W - 24F1	2S / 13W - 24B2
Flood Hazard ...	Negligible	Negligible

Maywood Mutual Water Company #1 – Manganese Blending Plan - 2009

Central Basin Metropolitan Water District

Maywood Mutual Water Company #1 also is tied into Central Basin Metropolitan Water District (CBMWD) the entry point is located on the corner of Pine Avenue and 60th Street in the city of Maywood and the water is designed to flow west towards our plant to help fill our tanks. CBMWD is design to flow into our water system at a maximum volume of 2900 gallons per minute. However, Maywood Mutual Water Co. #1 has set the volume at 1500 gallons/minute or less to enter our distribution system.

Standpipe Water Tanks

Maywood Mutual Water Company #1 has (2) water tanks.

- 1.) The small tank is 500,000 gallon maximum capacity; this tank measures 35 feet in diameters by 70 feet tall.
- 2.) The larger tank is 2,000,000 gallon maximum capacity; this tank measures 70 feet in diameters by 70 feet tall.
- 3.) Both tanks are interconnected and fill or drain at the same time. Any of these tanks can be isolated if the need arises. These tanks are located at the main plant at 5953 Gifford Ave., Huntington Park, CA

Plant Booster Pump Station

Maywood Mutual Water Company #1 has (3) three 40 hp booster pumps to supply our system pressure of 60psi. Maywood Mutual Water Company #1 uses only one booster pump at a time. The other two booster pumps are for redundancy purposes only.

The booster pumps take water from both tanks to pressurize the distribution system to 60 psi and return any over pressurized water back into our tanks. The booster pumps, pumps the water from our tanks to the back of our plant to Riverside Street heading south to 60th Street; any over pressurized water in the distribution system is return to the front of our plant on Gifford Avenue and return back into our tanks.

Typical Daily Operation – (Summer & Winter)

Maywood Mutual Water Company #1 adjusts to the water demand and makes changes accordingly. The summer demand is the highest. And we increase the level of water that the tanks hold. In the winter months or cooler periods of the year we maintain the water tank at lower levels.

Well #3 runs on a time basis only; the start time is 10:00 PM and stops at 10:00AM for a total of 12 hours. Well #3 produces 41,400 gallons per hour or 497,000 gallons per 12 hours. Well #3 pumps directly into the distribution system and water storage tanks.

Well #4 runs on time and level basis. When the desirer level is reached Well #4 will shut down. The start time is 10:00 PM and stops at 2:00AM only.

MWD may be used daily for at least 1 hour at this time to help fill and blend our water tanks.

Average Summer: Weekly and Monthly Water Demand To Water Tanks & Distribution System

(The following figures is based on maximum operation hours - 2007 - 2008)

WEEKLY

Well #3 . (720gpm)(60min/hr)(9hrs/day)(6days) =	2,333,000 gallons	40.24%
Well #4 . (920gpm)(60min/hr)(8hrs/day)(6days) =	2,649,600 gallons	45.70%
MWD	815,000 gallons	14.06%
	=====		=====
TOTAL >	5,797,600 gallons		100.0%

Maywood Mutual Water Company #1 – Manganese Blending Plan - 2009

MONTHLY (4 week period)

Well #3 (2.333mg/week)(4 weeks) =	9,332,000 gallons	40.24%
Well #4 (2.649mg/week)(4 weeks) =	10,598,400 gallons	45.70%
MWD (0.815mg/week)(4 weeks) =	3,260,000 gallons	14.06%
	=====	=====
TOTAL >	23,190,000 gallons	100.0%

Testing & Monitoring the Water Distribution System for Iron and Manganese Levels

Maywood Mutual Water Company #1 has since 2005 been monitoring the Iron and Manganese levels in the distribution system on a weekly basis. We have been monitoring the iron and manganese since 2005 on a every week. have

The Wells we monitor once every month. The other sites we monitor very week.

The following are the site that is the proposed sample locations for Iron and Manganese:

- 1.) **Sampling Station:** 4544 East 59th Street, Maywood, CA 90270 Weekly
- 2.) **Sampling Station:** 6110 South Gifford Avenue, Huntington Park, CA 90255 . . Weekly
- 3.) **Boosters:** 5953 Gifford Ave., Huntington Park, CA 90255 Weekly
- 4.) **Sampling Station:** 5953 Gifford Ave., Huntington Park, CA 90255 Weekly
- 5.) **Well #4:** 5953 Gifford Ave., Huntington Park, CA 90255 Monthly

- Site #1 is the far East side of our system.
- Site #2 is the Middle part of our system.
- Site #3 is our Booster (water to distribution system).
- Site #4 is at our main plant (water from distribution system into our tanks).
- Site #5 is our Well #4 (water to distribution system).

Monitoring will enabled Maywood Mutual Water Company #1 to plan as to when and where to flush our water mains to reduce increasing levels of iron, manganese or sediment from the water distribution system pipelines.

Maywood Mutual Water Company #1 has had very no complaints about orange, brown or black water coming out of the facets of customer’s homes in the past. Most complaints are about very short duration of yellowish water in the morning; usually 1 to 3 minutes and then it clears up. This has indicated to us that the problem is from old galvanized pipes in the homes; and not from the water system.

However the monitoring has indicated to us that our dead end areas do accumulate sedimentation more so than most of the other parts of our distribution system. Monitoring of the distribution system has helped us to keep the accumulate sedimentation from increasing in the distribution system by flushing that area about very 4 to 6 weeks.

We flush as close as possible to 5cfs to clean and eliminate most of the sedimentation that has accumulated in the water mains of our dead end areas and any inverted pipeline area. The other parts of are system is flush once every year or as needed.

The reduction in customer’s complaints and laboratory test records have indicated that accumulate sedimentation and manganese levels in the distribution system have been controlled to acceptable customer aesthetic levels.

Maywood Mutual Water Company #1 – Manganese Blending Plan - 2009

Public complaints in the City of Maywood

The city of Maywood and a community group Pro-Uno has been concern about the quality of the water. However, every complaint heard at these meeting has been about another water company that serves the city of Maywood. We have had very few complaints about the water in the city of Huntington Park.

There has been at least about (6) meetings that Maywood Mutual Water Company #1 has attended and we have written minutes of these meetings; three of these meetings we have audio recordings.

Procedures to Investigate Any Dirty Water Complaints

Maywood Mutual Water Company #1 has discovered that many residents do not realize that old galvanize pipes or mixing the pipes with copper and galvanize do produce yellowish water problem. Many residents have never flush the water heater that can also stain the laundry.

Every complaint that comes to Maywood Mutual Water Company #1 is investigated. Most times the water is coming out clear when we arrive to investigate at the location, but we still investigate the plumbing on the outside and under their homes to see the condition and material of their pipes.

The cities of Maywood and Huntington Park are older community and many homes still have the original piping when the home was built. Many of these homes were built in 1920's to the 1940's.

Within those years scale from the hard water and rust has filled inside these pipes and yellowish water is the result every morning or evening after disuse for a few hours. Most complaints investigation has lead to this conclusion.

We do not come across orangey or brown or black water in our investigations. If we do suspect that sedimentation in our pipelines maybe the problem; we do a thorough flushing of our water mains within the area. This will take care of the problem and return things to normal conditions again.

PROPOSE OPERATIONAL CHANGES FOR MAYWOOD MUTUAL WATER CO. #1 TO MEET THE SECONDARY MCL STANDARD FOR MANGANESE

Maywood Mutual Water Company #1 will be changing the operations to assure that the secondary standard for manganese, with a maximum contaminate level (MCL) is 50ug/l does not exceed the standard when it is boosted out into the water distribution system.

Maywood Mutual Water Company #1 proposes to run our well #3 to produce up to 60% to 65% of the daily production of water, and run Well #4 about 35% to 40% of the daily production of water. MWD imported water will be used off and on depending on the water demand for safe operations; or to blend if well #3 should need work or is off line for any reason.

The following is the theoretical calculations for Mn from all three water sources.

Table 1

The following is the theoretical calculations for Mn from two water sources.

Well #3		Well #4		MWD		Total
Design Flow GPM	690	Design Flow GPM	960	Design Flow GPM	0	1650
ug/Mn	10	ug/Mn	78	ug/Mn	0	88
Total	6900	Total	74880	Total	0	81780

Theoretical Calculations:	49.56 ug/l
MCL 50 ug/L - 80% MCL for Mn = 40 ug/l - Blend Goal <40 ug/L	

Maywood Mutual Water Company #1 – Manganese Blending Plan - 2009

Table 1 calculations are based on each well work at the same time, for the same amount of time. This is how we have been operating our plant plus some MWD water in past years.

However, Maywood Mutual Water Co. #1 is proposing running Well #4 only four hours a day. Well #3 will be running at least 12 hours a day. CBMWD will be used when water is needed to meet demand and 1 hour per day is anticipated as a daily use. These scenarios are calculated below in table 2, table 3 and table 4.

Table 2

TABLE 2						
Well #3		Well #4		MWD		Total
Design Flow GPM	690	Design Flow GPM	960	Design Flow GPM	1500	3150
Manganese ug/L	10	Manganese ug/L	78	Manganese ug/L	10	98
Total	6900	Total	74880	Total	15000	96780

Theoretical Calculations:

30.72 ug/l

MCL 50 ug/L - 80% MCL for Mn = 40 ug/l - Blend Goal <40 ug/L

Table 3

TABLE 3						
Well #3		Well #4		MWD		Total
Design Flow: Gals / 12 hrs	496800	Design Flow: Gal./ 4hrs	230400	Design Flow: Gals./ 1 hr	90000	817200
Manganese ug/L	10	ug/Mn	78	ug/Mn	10	98
Total	4968000	Total	17971200	Total	900000	23839200

Theoretical Calculations:

29.17 ug/l

MCL 50 ug/L - 80% MCL for Mn = 40 ug/l - Blend Goal <40 ug/L

Table 4

TABLE 4						
Well #3		Well #4		Total		
Design Flow: Gals / 12 hrs	496800	Design Flow: Gal./ 4hrs	230400		0	727200
ug/Mn	10	ug/Mn	78		0	88
Total	4968000	Total	17971200		0	22939200

Theoretical Calculations:

31.54 ug/l

MCL 50 ug/L - 80% MCL for Mn = 40 ug/l - Blend Goal <40 ug/L

Contingency plan:

Maywood Mutual Water Company #1 intends to follow this blending plan as outlined in table 2, table 3 or table 4. We should be able to blend our waters to be at or below our blending goal of <40 ug/L for manganese.

Maywood Mutual Water Company #1 will be; that all times on the alert for any failure to follow the blending plan. However, in case of failure for whatever cause Maywood Mutual Water Company #1 will immediately shut

Maywood Mutual Water Company #1 – Manganese Blending Plan - 2009

down the offending Well #4 water supply and turn on either well #3 or MWD to dilute the distribution water system at least 48 hours or and flush the distribution system if the manganese test levels are higher than our blending goal of <40ug/L.

Testing & Sampling procedure:

The following are the site that is the proposed sample locations for Iron and Manganese:

- 1.) **Sampling Station:** 4544 East 59th Street, Maywood, CA 90270 Weekly
- 2.) **Sampling Station:** 6110 South Gifford Avenue, Huntington Park, CA 90255 . . Weekly
- 3.) **Boosters:** 5953 Gifford Ave., Huntington Park, CA 90255 Weekly
- 4.) **Sampling Station:** 5953 Gifford Ave., Huntington Park, CA 90255 Weekly
- 5.) **Well #3:** 5953 Gifford Ave., Huntington Park, CA 90255 Monthly
- 6.) **Well #4:** 5953 Gifford Ave., Huntington Park, CA 90255 Monthly

- Site #1 is the far East side of our system.
- Site #2 is the Middle part of our system.
- Site #3 is our Booster (water out to distribution system).
- Site #4 is at our main plant (water coming from distribution system into our reservoirs).
- Site #5 is our Well #3 (water to distribution system to our reservoirs).
- Site #6 is our Well #4 (water to the reservoirs).

Weekly monitoring will enabled Maywood Mutual Water Company #1 to keep the blending plan working as proposed. Should there be a failure in our blending plan and high manganese levels are detected above the blending plan goal; we will immediately shut down well #4 which is the well with high manganese and stop production for at least 48 hours, before putting the well online again.

Maywood Mutual Water Co. #1 intends to purchase a hand held HACH DR/800 Series Colorimeters with offers simple, push-button program and step-by-step instructions that prompts the users through the testing procedure. This unit will enable us to test the manganese level at the plant everyday. We will be testing the water going out to the distribution system and the water coming back into our reservoirs.

Maywood Mutual Water Company #1 will also install a flow meter to the return main pipe that goes into our pump station and reservoirs. We will be able to monitor all waters that go into our tanks from the distribution system. We will be able to calculate exactly how much of that water is our well #3 or how much MWD is purchased as well as how much water is circulated by our booster; that goes back into our reservoirs.

Maywood Mutual Water Company #1 will also calculate the daily and weekly theoretical calculations by inputting these valves on an excel program to make sure that we are keeping with the blending goal of <40 ug/L for manganese. If our calculations indicate a problem, we will be able to react quickly to correct the problem.

System Design

Maywood Mutual Water Co. #1 basic pump and motor controls for our water distribution is as follows:

- Well #4 pumps directly into the reservoirs.
- Well #3 pumps directly into the water distribution system then to the reservoirs.
- Central Basin MWD interconnection flows directly into the water distribution system then to the reservoirs.
- Pump and motor controls and timing are made by programming our RTU unit.
- System pressure is regulated by 2 Cla-Vals at the pumping station.
- System pressure is maintain by one of three 40hp boosters or when well #3 is on.

Maywood Mutual Water Company #1 adjusts to the water demand and makes changes accordingly. The summer demand is the highest; we increase the level of water at the tanks. In the winter it will be less water in the tanks.

Maywood Mutual Water Company #1 – Manganese Blending Plan - 2009

Maywood Mutual Water Co. #1 will rely on well #3 and MWD as necessary to keep the blending plan at 40 ug/L Mn or below at all times.

Water Movement

Well #3 will operate at least 12 hours each day and Well #4 will operate 4 hours.

Well #3 pumps directly into the distribution system. The distribution system was design to allow most of the water that is pump to be diverted into the water tanks the distribution system works the same with MWD connection.

When well #3 is on, the water travels north on Carmelita Ave. to 60th Street then the water will travel east on 60th Street to Gifford Ave. and turn north again to our storage tanks. We have a 10 inch water main on Carmelita Ave., 60th Street and Gifford Ave. these are the main artery of the distribution system. Any excess water that is not being used by the system will be diverted into our tanks.

The branches to the rest of the water distribution system are 6” from north and south.

We plan on operating well #3 and well #4 in the evening, nights and early morning hours. Well#3 and well #4 will be operating at the same time; and when well #4 stops; well #3 will continue to operate until the 12 hours are up.

As the water is being pump by well #3 or purchasing water from CBMWD. The distribution system was design to allow as much water as possible to go to the pump station were we have 2 Cla-Vals or pressure relief valves that is set at 60 PSI. Once water is above 60 PSI the Cla-Vals will open and allow water into the tanks.

When ether Well #3 or MWD is operating the boosters at the pump station will not be operating.

We have been testing and adjusting formulas of running our wells since January 2009; and have had positive results from the laboratory analysis that the above mention plans are feasible.

Conclusion:

According to our calculations with a 50 / 50 blend of water from both wells we are still below the secondary MCL of 50 ug/l of manganese. However, Maywood Mutual Water Co. #1 is proposing to run are wells well below the threshold of secondary MCL level of 50 ug/l of manganese.

Maywood Mutual Water Co. #1 can meet and exceed reducing the levels of secondary MCL standard of 50 ug/L of manganese, by simply running our wells as table #2, #3 or #4 we will always be below the secondary MCL blending goal level of 40 ug/l of manganese in our water distribution system.

It is our desirer to provide the best potable water possible to our customers.

Maywood Mutual Water Co. #1 will continue to upgrade, repair and replace our infrastructure as we have in the past.

We hope this has satisfied the concerns of the California Department of Public Health (CADPH); and we look forward to your favorable response concerning our propose blending plan.

Sergio Palos
General Manager
Maywood Mutual Water Company #1

Maywood Mutual Water Company #1 – Manganese Blending Plan - 2009

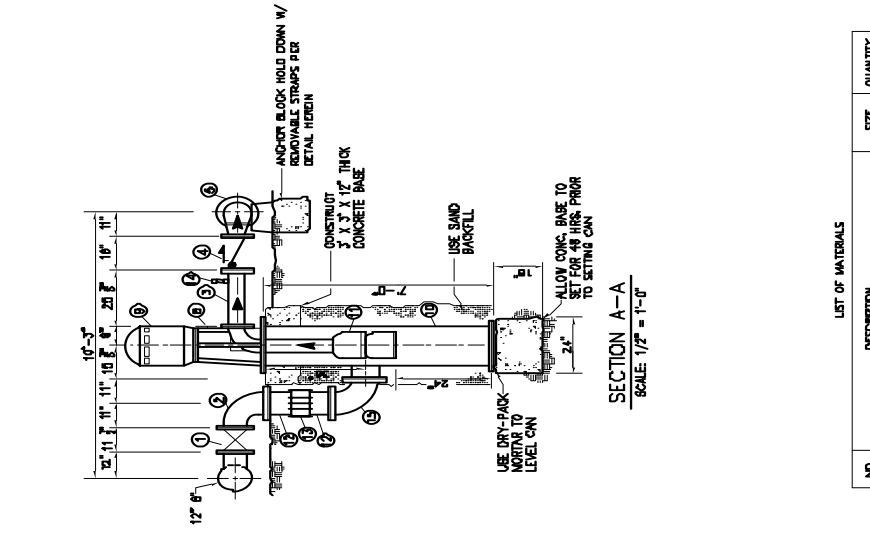

PLAN VIEW
SCALE 1/2" = 1'-0"

PUMP STATION AT 5953 CIFFORD AVE

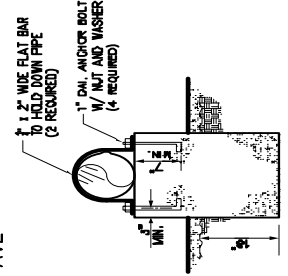

PIPE STRAP DETAIL
SCALE 1" = 1'-0"

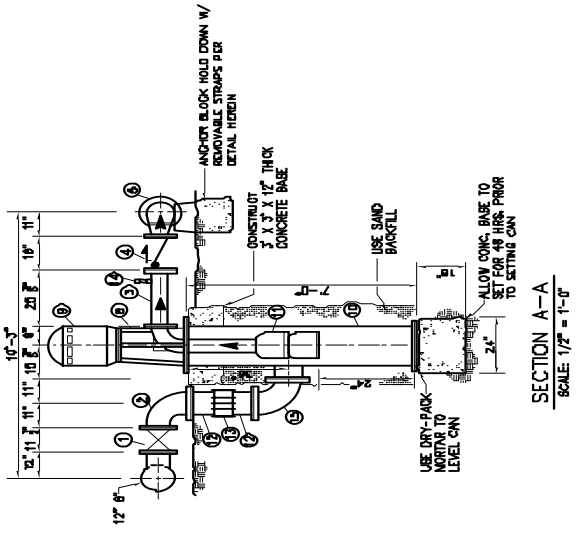

SECTION A-A
SCALE 1/2" = 1'-0"

LIST OF MATERIALS

NO.	DESCRIPTION	SIZE	QUANTITY
1	GATE VALVE F.L.G.	6"	1
2	84" REDUCING BEND F.L.G.	8" X 10"	1
3	STEEL SPOOL MORTAR LINED F.L.G. (SHP. 1 R.G. LORSE. INT. TO INT.)	6" X 30"	1
4	CHECK VALVE F.L.G.	6"	1
5	REDUCING BEND F.L.G.	10" X 6"	1
6	GATE VALVE F.L.G.	10"	1
7	STEEL SPOOL MORTAR LINED F.L.G. (SHP. 4 R.G. LORSE. INT. TO INT.)	10" X 30"	1
8	DISCHARGE HEAD	6"	1
9	MOTOR 40 H.P.	-	1
10	FABRICATED CAN WITH FLANGE BASE	16"	1
11	PUMP 1200 O.P.A.L. 105" T.S.H.	-	1
12	STEEL SPOOL MORTAR LINED F.L.G. X P.E.	10" X 12"	2
13	FLEXIBLE COUPLING	10"	1
14	CORPORATION STOP	7"	2
15	84" BEND F.L.G.	10"	1

FURNISHED BY OWNER

Maywood Mutual Water Company #1 – Manganese Blending Plan - 2009

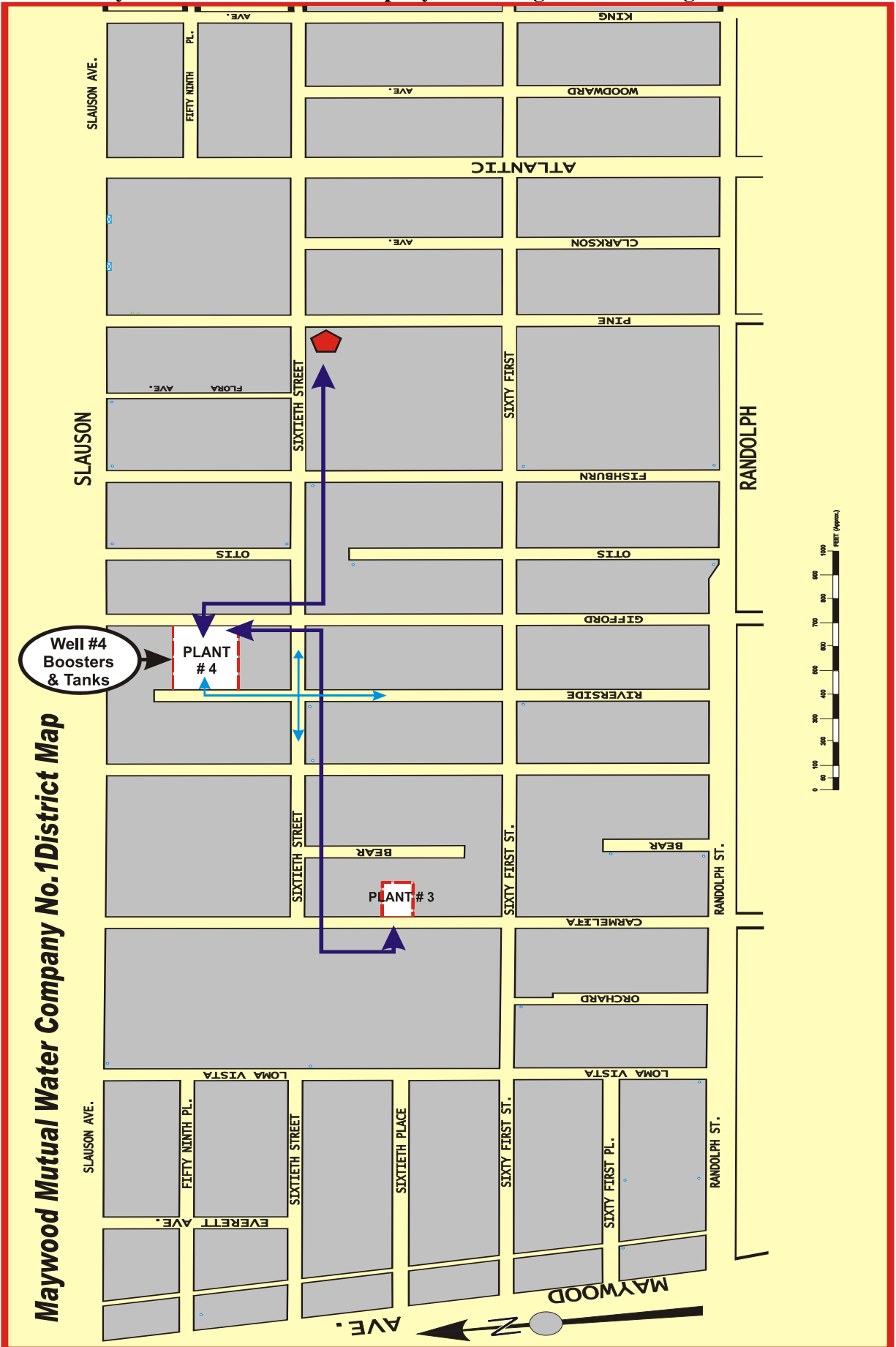

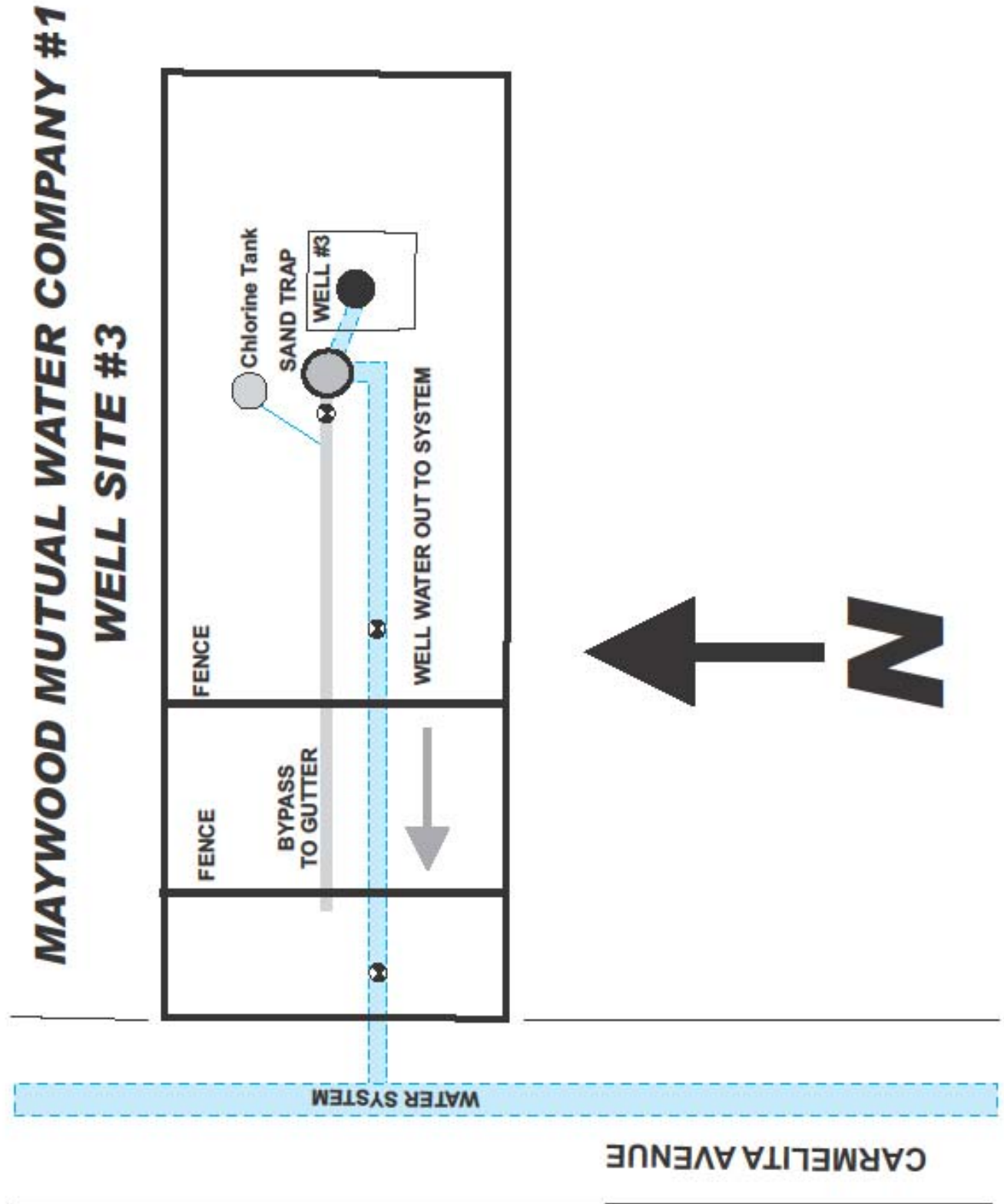

Maywood Mutual Water Company #1 – Manganese Blending Plan - 2009

MAYWOOD MUTUAL WATER CO. #1

 = FLOW DIRECTION FROM WELL #3 OR MWD

 = SYSTEM DESIGN FROM WELL #3 OR MWD

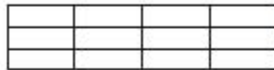
 = DISTRIBUTION SYSTEM

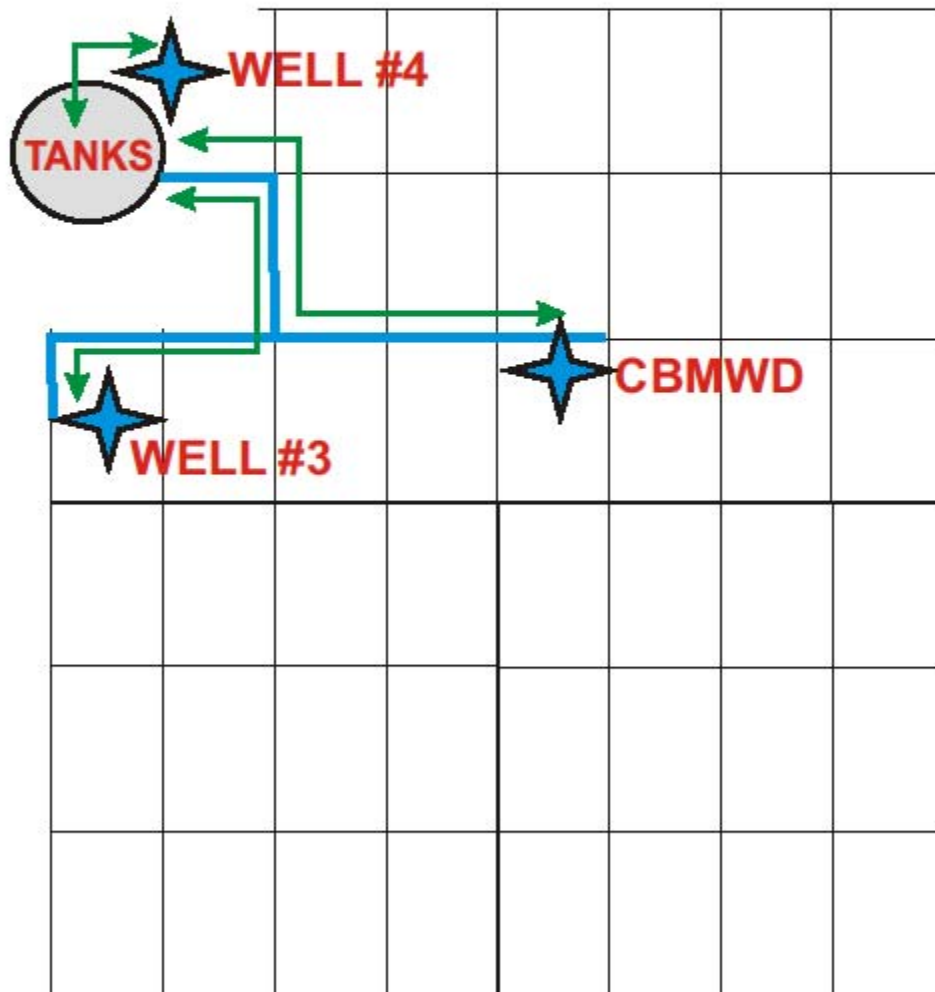

SYSTEM MANGANESE REPORTS - MAYWOOD MUTUAL WATER COMPANY #1 Blended Water

System Name: Maywood Mutual Water Co. #1 System No.: 1910084 Year: 2009 MONTH: OCTOBER

Year: 2009	JANUARY					FEBRUARY					MARCH					APRIL					MAY				
WEEK	1st	2nd	3rd	4th		1st	2nd	3rd	4th		1st	2nd	3rd	4th	5th	1st	2nd	3rd	4th		1st	2nd	3rd	4th	
(month/date):	1/5	1/12	1/20	1/26		2/2	2/9	2/17	2/23		3/2	3/9	3/17	3/24	3/30	4/6	4/13	4/20	4/27		5/4	5/11	5/18	5/26	
Site #1	38.0	23.0	28.0	ND		23.0	ND	ND	22.0		ND	23.0	ND	26.0	ND	ND	ND	ND	21.0		ND	26.0	ND	22.0	

Year: 2009	JUNE					JULY					AUGUST					SEPTEMBER					OCTOBER				
WEEK	1st	2nd	3rd	4th	5th	1st	2nd	3rd	4th		1st	2nd	3rd	4th		1st	2nd	3rd	4th		1st	2nd	3rd	4th	
(month/date):	6/1	6/8	6/15	6/22	6/29	7/6	7/13	7/20	7/27		8/3	8/10	8/17	8/20	8/24	9/8	9/12	9/21	9/28		10/5	10/12	10/19	10/26	
Site #1	ND	ND	ND	ND	40.0	ND	25.0	20.0	ND		ND	ND	ND	12.0	1/15	31.0	ND	ND	ND		ND	ND	ND	30.0	

Tested for low levels-see test sheet

Year: 2009	NOVEMBER					DECEMBER				
WEEK	1st	2nd	3rd	4th	5th	1st	2nd	3rd	4th	
(month/date):	11/2	11/9	11/16	11/23	11/30	12/1	12/8	12/15	12/22	
Site #1	ND			26.0	30.0	30.0	25.0	24.0	24.0	

MANGANESE Detection Level = 20ug/l - MANGANESE MCL = 50ug/l

Identify the sample locations in the table below.

Site	Sample Location
1	4544 East 59th Place, Maywood, CA 90270 - (East End of System)

(*) = Test America - Irvine (Formerly Del Mar)

Maywood Mutual Water Company #1 • Accomplishments & System Needs

The Managing Board of Directors and General Manager of Maywood Mutual Water Company #1 main concern has always been to provide sound financial management with a proactive approach to our water infrastructure needs and to always provide clean, safe, wholesome potable drinking water to our customers.

In these past few years Maywood Mutual Water Company #1 has aggressively been updating our water system. This is done for the safety and reliability of our local water supply. The General Manager and Board of Directors are committed to improving our community water system.

Through careful management and cost-saving measures Maywood Mutual Water Company #1 has been able to accomplish many necessary upgrades within existing resources despite rising energy and other production costs. Maywood Mutual Water Company #1 has also been paying increased fees this year to local, county and state water agencies.

The following are a few of the projects Maywood Mutual Water #1 has done to improve the water system for our community.

- Replacement of over 10,000 feet (2 miles) of old 4" pipeline at the east end (Maywood side) of our system 2007
- Upgraded to 8 inch PVC non-corrosive pipeline as replacement pipes 2007
- Installed over 40 new street valves 2007
- New copper service connections for 250 customers 2007
- 10 new fire hydrants at the east end of our system to provide excellent fire protection to the area 2007
- Back-flow prevention program started along Atlantic Avenue 2007
- Installed 10 - 3" and larger commercial meters 2008
- Installed 5 large meter vaults 2008
- Cleaned the interior of our 2 million gallon water tank 2008
- Installed additional (2) Two additional 200 gallon chlorine tanks one at each well site 2008
- Secured and replaced stolen fire hydrants to stop the theft 2008
- Finish paying off all water main replacement project 2008
- Added equipment to our inventory to include a Volvo backhoe 2009
- Pipeline through the intersection of Slauson Ave. and Atlantic Ave. with tie-in on 10 inch water main 2009
- Started valve replacement program 2 or 4 valves per month 2009
- Improve security in yard by adding lights in the yard 2009
- Booster station upgrade with new more efficient pump 2009
- Applied for 7 Federal grants for over 10 million dollars 2009
- Installing modern computerized controls to monitor all wells, motors for better efficiency 2009
- (40) new customer copper water service lines on 60th Street, Fishburn Ave. and Riverside Ave. 2010
- Two (2) water tanks cleaned out 2010
- Applied for state grant for new treatment plant 2010

Maywood Mutual Water Company #1 has spent over 2.5 Million Dollars in improvements to our water system since 2002 when this present management took over the day to day duties of the Water Company.

Our dedication to improve your water system is not only in words, but in deeds. Even with all the work and improvements that have been done; in our aging water system, much work still remains to be completed. Merely replacing or rehabilitating our storage tanks, additional water lines and the rehabilitation of our water well #4 alone will cost in excess of six million dollars.

Maywood Mutual Water Company #1 has purchased a backhoe, with this equipment our crew will now be able to start changing out the old valves and customer service lines in our system. This will save many thousands of dollars instead of hiring pipeline contractors.

Other maintenance programs such as fire hydrant flushing, painting, meters and general maintenance of our well sites is always ongoing.

The cost of imported water has risen 20% this year and may increase more in the future, due to the drought that has struck California. Voluntary conservation of water must become necessary in order to have enough water for the remainder of the year or water levels in the reservoirs will be reduced even more.

Nonetheless, the general manager and Board of Directors is committed to providing safe, wholesome and potable drinking water with quality service to our customers, by keeping a sufficient supply of water, responding to any customers concerns at any hour or day, maintaining an aggressive preventative maintenance program, repairing valves or water mains when needed and upgrading the water system when opportunity presents itself. Maintaining and improving our system will require diligences and commitment.

Informe De Confianza De Consumidor Del Año 2009 2009 Consumer Confidence Report

Huntington Park, California 90255
5953 South Gifford Avenue

MAYWOOD
MUTUAL WATER CO. #1

Este informe contiene información muy importante sobre su agua potable. Para más información llame a (323) 560-2439

How Can I Conserve Water At Home?

Install a low-flow showerhead & save over 5 gallons of water per shower, or about 1,800 gallons per year per person!

Install a low-flow toilet or displacement device in your toilet - save 3.5 to 4.5 gals on every flush!

Run full loads in your washing machine / dishwasher - save 300 - 800 gallons per month!

Sweep your sidewalks and driveways - save 250 gallons each time by sweeping instead of hosing!

Water the lawn only when it needs it - save 50 to 100 gallons per day!

MAYWOOD MUTUAL WATER CO. #1

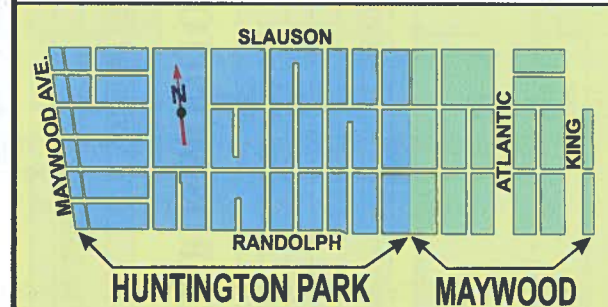

SERVICE AREA

¿Cómo puedo conservar Agua En Casa?

¡Instale una regadera de flujo bajo y ahorre más de 5 galones cada vez que se bane, o más de 1.800 galones por año por persona!

¡Instale un inodoro de flujo bajo o reemplaze la bomba dentro del tanque de su tasa - ahorre de 3.5 galones a 4.5 galones por uso!

¡De marcha a sus lavadora/lavaplatos solo con carga llenas - ahorre de 300 - 800 galones al mes!

¡Barra las banquetas y cocheras - ahorre 250 galones de agua cada hora con la escoba en vez de regar!

¡Riegue el césped solo cuando sea necesario - ahorre 50 a 100 galones por día!

This Report has important information about your water. Please call our office if you have any concerns at (323) 560-2439

Maywood Mutual Water Company No.1

2009 CONSUMER CONFIDENCE REPORT

Since 1991, California water utilities have been providing information on water served to its consumers. This report is a snapshot of the tap water quality that we provided last year. Included are details about where your water comes from, how it is tested, what is in it, and how it compares with state and federal limits. We strive to keep you informed about the quality of your water, and to provide a reliable and economic supply that meets all regulatory requirements.

MAYWOOD MUTUAL WATER CO. #1

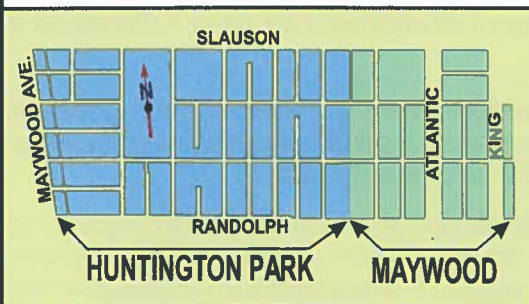

SERVICE AREA

Where Does My Tap Water Come From?

Your tap water comes from 2 sources: groundwater and surface water. We pump groundwater from local, deep wells. We also use Metropolitan Water District of Southern California's (MWD) surface water from both the Colorado River and the State Water Project in northern California. These water sources supply our service area shown on the adjacent map. The quality of our groundwater and MWD's surface water supplies is presented in this report.

How is My Drinking Water Tested?

Your drinking water is tested regularly for unsafe levels of chemicals, radioactivity and bacteria at the source and in the distribution system. We test weekly, monthly, quarterly, annually or less often depending on the substance. State and federal laws allow us to test some substances less than once per year because their levels do not change frequently. All water quality tests are conducted by specially trained technicians in state-certified laboratories.

What Are Drinking Water Standards?

The U.S Environmental Protection Agency (USEPA) limits the amount of certain substances allowed in tap water. In California, the State Department of Public Health (Department) regulates tap water quality by enforcing limits that are at least as stringent as the USEPA's. Historically, California limits are more stringent than the Federal ones.

There are two types of these limits, known as standards. Primary standards protect you from substances that could potentially affect your health. Secondary standards regulate substances that affect the aesthetic qualities of water. Regulations set a Maximum Contaminant Level (MCL) for each of the primary and secondary standards. The MCL is the highest level of a substance that is allowed in your drinking water.

Public Health Goals (PHGs) are set by the California Environmental Protection Agency. PHGs provide more information on the quality of drinking water to customers, and are similar to their federal counterparts, Maximum Contaminant Level Goals (MCLGs). PHGs and MCLGs are advisory levels that are nonenforceable. Both PHGs and MCLGs are concentrations of a substance below which there are no known or expected health risks.

How Do I Read the Water Quality Table?

Although we test for over 100 substances, regulations require us to report only those found in your water. The first column of the water quality table lists substances detected in your water. The next columns list the average concentration and range of concentrations found in your drinking water. Following are columns that list the MCL and PHG or MCLG, if appropriate. The last column describes the likely sources of these substances in drinking water.

To review the quality of your drinking water, compare the highest concentration and the MCL. Check for substances greater than the MCL. Exceedence of a primary MCL does not usually constitute an immediate health threat. Rather, it requires testing the source water more frequently for a short duration. If test results show that the water continues to exceed the MCL, the water must be treated to remove the substance, or the source must be removed from service.

Why Do I See So Much Coverage in the News About the Quality Of Tap Water?

The sources of drinking water (both tap water and bottled water) include rivers, lakes, streams, ponds, reservoirs, springs and wells. As water travels over the surface of the land or through the ground, it dissolves naturally occurring minerals and, in some cases, radioactive material, and can pick up substances resulting from the presence of animals or from human activity;

Contaminants that may be present in source water include:

- Microbial contaminants, including viruses and bacteria, that may come from sewage treatment plants, septic systems, agricultural livestock operations, and wildlife;
- Inorganic contaminants, such as salts and metals, that can be naturally-occurring or result from urban stormwater runoff, industrial or domestic wastewater discharges, oil and gas production, mining or farming;
- Pesticides and herbicides, which may come from a variety of sources such as agriculture, urban stormwater runoff, and residential uses;
- Organic chemical contaminants, including synthetic and volatile organic chemicals, that are byproducts of industrial processes and petroleum production, and can also come from gas stations, urban stormwater runoff, agricultural application, and septic systems;
- Radioactive contaminants, which can be naturally occurring or be the result of oil and gas production and mining activities.

In order to ensure that tap water is safe to drink, the USEPA and the Department prescribe regulations that limit the amount of certain contaminants in water provided by public water systems. Department regulations also establish limits for contaminants in bottled water that must provide the same protection for public health.

All drinking water, including bottled water, may reasonably be expected to contain at least small amounts of some contaminants. The presence of contaminants does not necessarily indicate that water poses a health risk. More information about contaminants and potential health effects can be obtained by calling the USEPA's Safe Drinking Water Hotline (1-800-426-4791). You can also get more information on tap water by logging on to these helpful web sites:

- www.epa.gov/OGWDW (USEPA's web site)
- www.cdph.ca.gov (Department of Public Health web site)

Should I Take Additional Precautions?

Some people may be more vulnerable to contaminants in drinking water than the general population. Immunocompromised persons such as persons with cancer undergoing chemotherapy, persons who have undergone organ transplants, people with HIV/AIDS or other immune system disorders, some elderly, and infants can be particularly at risk from infections. These people should seek advice about drinking water from their health care providers. The USEPA/Centers for Disease Control guidelines on appropriate means to lessen the risk of infection of *Cryptosporidium* and other microbial contaminants are available from the USEPA's Safe Drinking Water Hotline by calling: (1-800-426-4791).

Source Water Assessment

MWD completed an assessment of its Colorado River and State Water Project supplies in 2002. Colorado River supplies are considered most vulnerable to recreation, urban/storm water runoff, increasing urbanization in the watershed, and wastewater. State Water Project supplies are considered most vulnerable to urban/storm water runoff, wildlife, agriculture, recreation and wastewater. A copy of the assessment can be obtained by contacting MWD at (213) 217-6850.

Maywood Mutual Water Company No. 1 conducted an assessment of its groundwater supplies in May of 2003. Groundwater supplies are considered most vulnerable to historic gas stations, chemical/petroleum processing/storage, metal plating/finishing/fabricating, automobile body shops, automobile gas stations, and dry cleaners. A copy of the approved assessment may be obtained by contacting the main office.

How Can I Participate in Decisions On Water Issues That Affect Me?

All shareholders our welcome to attend Board meetings on the third Monday of each month at 11:00 a.m., and the annual shareholders meeting the third Saturday of July at 11:00 a.m. at 5953 South Gifford Ave., Huntington Park, CA 90255.

How Do I Contact My Water Agency If I Have Any Questions About Water Quality?

If you have specific questions about your tap water quality, please contact Sergio Palos at (323) 560-2439.

Maywood Mutual Water Company #1 Mission Statement

"Maywood Mutual Water Company No. 1, shall deliver to our shareholders a reliable supply of quality drinking water through preventative maintenance, efficient pumping and distribution methods, informing and servicing our customers, in a professional and courteous manner"

Maywood Mutual Board of Directors for 2009 - 2010

Sergio Palos President / Gen. Manager	Donald Jervis Treasurer	Giovanni Samayoa Board Member	Orley Waite Board Member	Guillermo Sánchez Secretary
--	----------------------------	----------------------------------	-----------------------------	--------------------------------

MAYWOOD MUTUAL WATER COMPANY No. 1 2009 CONSUMER CONFIDENCE REPORT

Results are from the most recent testing performed in accordance with state and federal drinking water regulations. The State allows the monitoring for some contaminants less than once per year because the concentrations of these contaminants do not change frequently. Some of the data, though representative, are more than one year old.

PRIMARY STANDARDS MONITORED AT THE SOURCE - MANDATED FOR PUBLIC HEALTH

ORGANIC CHEMICALS	GROUNDWATER		MWD'S SURFACE WATER		PRIMARY MCL	MCLG or PHG	MAJOR SOURCES IN DRINKING WATER
	AVERAGE (a)	RANGE (a)	AVERAGE (a)	RANGE (a)			
INORGANIC - Sampled from 2007 to 2009 (b)							
Aluminum (mg/l)	0.01	ND - 0.02	0.14	ND - 0.24	1	0.6 (c)	Erosion of natural deposits; residue from surface water treatment processes
Arsenic (µg/l)	ND	ND	2.5	ND - 3.9	10	0.004	Erosion of natural deposits; glass/electronics production wastes; runoff
Barium (mg/l)	0.15	0.12 - 0.16	0.08	ND - 0.14	1	2 (c)	Oil drilling waste and metal refinery discharge; erosion of natural deposits
Fluoride (mg/l) (l)	0.43	0.42 - 0.44	0.80	0.6 - 1.0	2.0	1 (c)	Erosion of natural deposits; water additive that promotes strong teeth
Nitrate (mg/l as NO3)	1.40	ND - 2.80	2.30	0.9 - 4.2	45	45 (c)	Runoff and leaching from fertilizer use/septic tanks/sewage; natural erosion
Perchlorate (µg/l)	ND	ND	ND	ND	6	6	Perchlorate is an inorganic chemical used in solid rocket propellant, fireworks, explosives, flares, matches and a variety of industries. It usually gets into drinking water as a result of environmental contamination from historic aerospace or other industrial operations that used or use, store or dispose of perchlorate and its salts.

RADIOLOGICAL - (pCi/l) Analyzed 4 consecutive quarters every 4 years (results are from 2006 to 2009) (b)

Gross Alpha	0.4	0.4	4.7	ND - 9.3	15 (c)	0	Erosion of natural deposits
Gross Beta	NA	NA	2.8	ND - 9.7	50 (e)	0	Decay of natural and man made deposits
Radium 226	NA	NA	ND	ND	5 (d)	0.05	Erosion of natural deposits
Radium 228	0.83	ND - 1.7	ND	ND	5 (d)	0.019	Erosion of natural deposits
Uranium	0.75	ND - 1.5	2.7	1.6 - 3.7	20 (e)	0.43 (g)	Erosion of natural deposits

PRIMARY STANDARDS MONITORED AT THE DISTRIBUTION SYSTEM - MANDATED FOR PUBLIC HEALTH

MICROBIALS	DISTRIBUTION SYSTEM		PRIMARY MCL	MCLG or PHG
	AVERAGE # POSITIVE	RANGE OF # POSITIVE		
Total Coliform Bacteria	0	0	< 1 positive	0
Fecal Coliform and E. Coli Bacteria	0	0	0	0
No. of Acute Violations	0	0	-	-

MICROBIALS	DISTRIBUTION SYSTEM	
	AVERAGE	RANGE
Turbidity (NTU)	0.3	< 0.1 - 1.2

DISINFECTION BY-PRODUCTS AND DISINFECTION RESIDUALS (f)

	DISTRIBUTION SYSTEM		PRIMARY MCL	MCLG or PHG
	AVERAGE	RANGE		
Total Trihalomethanes - TTHMs (µg/l)	46.4	ND - 20.9	80	-
Haloacetic Acids (µg/l)	14.9	ND - 3.6	60	-
Total Chlorine Residual (mg/l)	0.6	0.57 - 0.75	4.0 (g)	4.0 (h)

AT THE TAP PHYSICAL CONSTITUENTS 25 sites sampled in 2007

	DISTRIBUTION SYSTEM		PRIMARY MCL	MCLG or PHG
	90%ile	# OF SITES ABOVE THE AL		
Copper (mg/l)	ND (j)	0	1.3 AL	0.17 (c)
Lead (µg/l)	ND (i)	0	15 AL	2 (c)

Internal corrosion of household plumbing, erosion of natural deposits
Internal corrosion of household plumbing, industrial manufacturer discharges

SECONDARY STANDARDS MONITORED AT THE SOURCE - FOR AESTHETIC PURPOSES

Sampled from 2007 to 2009 (b)

	GROUNDWATER		MWD'S SURFACE WATER		SECONDARY MCL	MCLG or PHG
	AVERAGE	RANGE	AVERAGE	RANGE		
Aggressiveness Index (corrosivity)	12.8	12.4 - 13	12.1	12.0 - 12.4	Non-Corrosive	-
Aluminum (µg/l) (j)	6	ND - 18	135	ND - 240	200	600 (c)
Chloride (mg/l)	54.3	50 - 58	91	77 - 100	500	-
Color (color units)	ND	ND	2	1 - 2	15	-
Conductivity (uS/cm)	680	660 - 700	863.3	570 - 1100	1600	-
Iron (µg/l)	74.9	ND - 200	ND	ND	300	-
Langlier Index (corrosivity) (SI)	0.46	0.46	NA	NA	Non-Corrosive	-
Manganese (µg/l)	41.1	ND - 92 (k)	ND	ND	50	-
Odor (threshold odor number)	0.5	ND - 1	2	2.0	3	-
Sulfate (mg/l)	106.7	100 - 120	182	56 - 260	500	-
Total Dissolved Solids (mg/l)	396.7	370 - 420	520	310 - 660	1,000	-
Turbidity (NTU)	0.24	ND - 0.85	0.05	0.04 - 0.06	5	-

Natural/industrially-influenced balance of hydrogen/carbon/oxygen in water
Erosion of natural deposits, surface water treatment process residue
Runoff / leaching from natural deposit, seawater influence
Naturally - occurring organic materials
Substances that form ions when in water; seawater influence
Leaching from natural deposits; industrial wastes
Natural/industrially-influenced balance of hydrogen/carbon/oxygen in water
Leaching from natural deposits
Naturally - occurring organic materials
Runoff / leaching from natural deposits, industrial wastes
Runoff / leaching from natural deposits
Soil runoff

SECONDARY STANDARDS MONITORED AT THE DISTRIBUTION SYSTEM - FOR AESTHETIC PURPOSES

GENERAL PHYSICAL CONSTITUENTS	DISTRIBUTION SYSTEM		SECONDARY MCL	MCLG or PHG
	AVERAGE	RANGE		
Color (color units)	6	< 3 - 10		
Odor (threshold odor number)	1	1.0		

Naturally - occurring organic materials
Naturally - occurring organic materials

ADDITIONAL CHEMICALS OF INTEREST

Sampled in 2007 - 2009 (b)

	GROUNDWATER		MWD'S SURFACE WATER	
	AVERAGE	RANGE	AVERAGE	RANGE
Alkalinity (mg/l)	160	150 - 180	110	84 - 130
Boron (µg/l)	180	180	153	120 - 220
Bromate (µg/l)	NA	NA	NA	NA
Calcium (mg/l)	66.7	63 - 71	56	27 - 76
Magnesium (mg/l)	15	14 - 16	22.3	11 - 30
N-Nitrosodimethylamine (ng/l)	NA	NA	2.03	ND - 5.1
pH (standard unit)	7.7	7.5 - 7.9	8.0	7.8 - 8.0
Potassium (mg/l)	3.7	3.6 - 3.7	4.1	2.6 - 5.3
Silica (mg/l)	28	28	NA	NA
Sodium (mg/l)	54	53 - 55	88.3	66 - 100
Total Hardness (mg/l)	230	210 - 240	230	120 - 310
Total Organic Carbon (mg/l)	1.1	1.1	2.1	1.2 - 2.6
Vanadium (µg/l)	ND	ND	4.2	ND - 6.7

ABBREVIATIONS

ABBREVIATIONS: NA = constituent not analyzed • NTU = nephelometric turbidity
uS/cm = Microsims per centimeter = a measure of electrical conductivity
ND = constituent not detected at the reporting limit
< = less than • SI = saturation index • pCi/l = picoCuries per liter
mg/l = milligrams per liter or parts per million . . . (equivalent to 1 drop in 42 gallons)
µg/l = micrograms per liter or parts per billion . . . (equivalent to 1 drop in 42,000 gallons)
ng/l = nanograms per liter or parts per trillion . . . (equivalent to 1 drop in 42,000,000 gallons)

FOOTNOTES

- Over 50 regulated and unregulated organic chemicals were analyzed. None were detected at or above the reporting limit in groundwater or surface water sources.
- Indicates dates sampled for groundwater sources only.
- California Public Health Goal (PHG). Other advisory levels listed in this column are federal Maximum Contaminant Level Goals (MCLGs).
- Combined Radium 226 + Radium 228 has a Maximum Contaminant Level (MCL) of 5 pCi/L.
- MCL compliance based on 4 consecutive quarters of sampling.
- Running annual average used to calculate average, range, and MCL compliance.
- Maximum Residual Disinfectant Level (MRDL)
- Maximum Residual Disinfectant Level Goal (MRDLG)
- 90th percentile from the most recent sampling at selected customer taps.
- Aluminum has primary and secondary standards.
- The secondary MCL for manganese was exceeded in one (1) out of two (2) wells in 2009. Manganese has been detected at elevated levels since 1995 and has been monitored monthly or quarterly since. Groundwater is blended with surface water before delivery to the customer, which dilutes the amount of manganese actually reaching the tap. Manganese samples taken weekly in the distribution system averaged well below regulatory limits. The manganese MCL is set to protect against unpleasant effects such as color, taste, odor, and staining of laundry/plumbing fixtures. A manganese secondary MCL exceedance does not pose a health risk.
- MWD started adding flouride at each treatment plant in the fall of 2007. MWD was in compliance with the provisions of the State's requirements.

DEFINITIONS

DEFINITIONS: **Maximum Contaminant Level (MCL):** The highest level of a contaminant that is allowed in drinking water. **Primary MCLs** are set as close to the PHGs (or MCLGs) as is economically and technologically feasible. **Secondary MCLs** are set to protect the odor, taste, and appearance of drinking water. **Maximum Contaminant Level Goal (MCLG):** The level of a contaminant in drinking water below which there is no known or expected risk to health. **MCLGs** are set by the U.S. Environmental Protection Agency. **Maximum Residual Disinfectant Level (MRDL):** The highest level of a disinfectant allowed in drinking water. There is convincing evidence that addition of a disinfectant is necessary for control of microbial contaminants. **Public Health Goal (PHG):** The level of a contaminant in drinking water below which there is no known or expected risk to health. **PHGs** are set by the California Environmental Protection Agency. **Treatment Technique (TT):** A required process intended to reduce the level of a contaminant in drinking water. **Regulatory Action Level (AL):** The concentration of a contaminant which, if exceeded, triggers treatment or other requirements that a water system must follow. **Primary Drinking Water Standard (PDWS):** MCLs and MRDLs for contaminants that affect health along with their monitoring and reporting requirements, and water treatment requirements.

MAYWOOD MUTUAL WATER COMPANY No. 1 2009 CONSUMER CONFIDENCE REPORT

Results are from the most recent testing performed in accordance with state and federal drinking water regulations. The State allows the monitoring for some contaminants less than once per year because the concentrations of these contaminants do not change frequently. Some of the data, though representative, are more than one year old.

PRIMARY STANDARDS MONITORED AT THE SOURCE - MANDATED FOR PUBLIC HEALTH

ORGANIC CHEMICALS	GROUNDWATER		MWD'S SURFACE WATER		PRIMARY MCL	MCLG or PHG	MAJOR SOURCES IN DRINKING WATER
	AVERAGE (a)	RANGE (a)	AVERAGE (a)	RANGE (a)			
INORGANIC - Sampled from 2007 to 2009 (b)							
Aluminum (mg/l)	0.01	ND - 0.02	0.14	ND - 0.24	1	0.6 (c)	Erosion of natural deposits; residue from surface water treatment processes
Arsenic (µg/l)	ND	ND	2.5	ND - 3.9	10	0.004	Erosion of natural deposits; glass/electronics production wastes; runoff
Barium (mg/l)	0.15	0.12 - 0.16	0.08	ND - 0.14	1	2 (c)	Oil drilling waste and metal refinery discharge; erosion of natural deposits
Fluoride (mg/l) (l)	0.43	0.42 - 0.44	0.80	0.6 - 1.0	2.0	1 (c)	Erosion of natural deposits; water additive that promotes strong teeth
Nitrate (mg/l as NO ₃)	1.40	ND - 2.80	2.30	0.9 - 4.2	45	45 (c)	Runoff and leaching from fertilizer use/septic tanks/sewage; natural erosion
Perchlorate (ug/l)	ND	ND	ND	ND	6	6	Perchlorate is an inorganic chemical used in solid rocket propellant, fireworks, explosives, flares, matches and a variety of industries. It usually gets into drinking water as a result of environmental contamination from historic aerospace or other industrial operations that used or use, store or dispose of perchlorate and its salts.

RADIOLOGICAL - (pCi/l) Analyzed 4 consecutive quarters every 4 years (results are from 2006 to 2009) (b)

Gross Alpha	0.4	0.4	4.7	ND - 9.3	15 (c)	0	Erosion of natural deposits
Gross Beta	NA	NA	2.8	ND - 9.7	50 (e)	0	Decay of natural and man made deposits
Radium 226	NA	NA	ND	ND	5 (d)	0.05	Erosion of natural deposits
Radium 228	0.83	ND - 1.7	ND	ND	5 (d)	0.019	Erosion of natural deposits
Uranium	0.75	ND - 1.5	2.7	1.6 - 3.7	20 (e)	0.43 (g)	Erosion of natural deposits

PRIMARY STANDARDS MONITORED AT THE DISTRIBUTION SYSTEM - MANDATED FOR PUBLIC HEALTH

MICROBIALS	DISTRIBUTION SYSTEM		PRIMARY MCL	MCLG or PHG
	AVERAGE # POSITIVE	RANGE OF # POSITIVE		
Total Coliform Bacteria	0	0	< 1 positive	0
Fecal Coliform and E. Coli Bacteria	0	0	0	0
No. of Acute Violations	0	0	-	-

MICROBIALS	DISTRIBUTION SYSTEM	
	AVERAGE	RANGE
Turbidity (NTU)	0.3	< 0.1 - 1.2

DISINFECTION BY-PRODUCTS AND DISINFECTION RESIDUALS (f)

	DISTRIBUTION SYSTEM		PRIMARY MCL	MCLG or PHG
	AVERAGE	RANGE		
Total Trihalomethanes - TTHMS (µg/l)	46.4	ND - 20.9	80	-
Haloacetic Acids (µg/l)	14.9	ND - 3.6	60	-
Total Chlorine Residual (mg/l)	0.6	0.57 - 0.75	4.0 (g)	4.0 (h)

AT THE TAP PHYSICAL CONSTITUENTS 25 sites sampled in 2007

	DISTRIBUTION SYSTEM		PRIMARY MCL	MCLG or PHG
	90%ile	# OF SITES ABOVE THE AL		
Copper (mg/l)	ND (j)	0	1.3 AL	0.17 (c)
Lead (µg/l)	ND (i)	0	15 AL	2 (c)

Internal corrosion of household plumbing, erosion of natural deposits
Internal corrosion of household plumbing, industrial manufacturer discharges

SECONDARY STANDARDS MONITORED AT THE SOURCE - FOR AESTHETIC PURPOSES

Sampled from 2007 to 2009 (b)

	GROUNDWATER		MWD'S SURFACE WATER		SECONDARY MCL	MCLG or PHG
	AVERAGE	RANGE	AVERAGE	RANGE		
Aggressiveness Index (corrosivity)	12.8	12.4 - 13	12.1	12.0 - 12.4	Non-Corrosive	-
Aluminum (µg/l) (j)	6	ND - 18	135	ND - 240	200	600 (c)
Chloride (mg/l)	54.3	50 - 58	91	77 - 100	500	-
Color (color units)	ND	ND	2	1 - 2	15	-
Conductivity (uS/cm)	680	660 - 700	863.3	570 - 1100	1600	-
Iron (µg/l)	74.9	ND - 200	ND	ND	300	-
Langlier Index (corrosivity) (SI)	0.46	0.46	NA	NA	Non-Corrosive	-
Manganese (µg/l)	41.1	ND - 92 (k)	ND	ND	50	-
Odor (threshold odor number)	0.5	ND - 1	2	2.0	3	-
Sulfate (mg/l)	106.7	100 - 120	182	56 - 260	500	-
Total Dissolved Solids (mg/l)	396.7	370 - 420	520	310 - 660	1,000	-
Turbidity (NTU)	0.24	ND - 0.85	0.05	0.04 - 0.06	5	-

Natural/industrially-influenced balance of hydrogen/carbon/oxygen in water
Erosion of natural deposits, surface water treatment process residue
Runoff / leaching from natural deposit, seawater influence
Naturally - occurring organic materials
Substances that form ions when in water; seawater influence
Leaching from natural deposits; industrial wastes
Natural/industrially-influenced balance of hydrogen/carbon/oxygen in water
Leaching from natural deposits
Naturally - occurring organic materials
Runoff / leaching from natural deposits, industrial wastes
Runoff / leaching from natural deposits
Soil runoff

SECONDARY STANDARDS MONITORED AT THE DISTRIBUTION SYSTEM - FOR AESTHETIC PURPOSES

GENERAL PHYSICAL CONSTITUENTS	DISTRIBUTION SYSTEM		SECONDARY MCL	MCLG or PHG
	AVERAGE	RANGE		
Color (color units)	6	< 3 - 10		
Odor (threshold odor number)	1	1.0		

Naturally - occurring organic materials
Naturally - occurring organic materials

ADDITIONAL CHEMICALS OF INTEREST

Sampled in 2007 - 2009 (b)

	GROUNDWATER		MWD'S SURFACE WATER	
	AVERAGE	RANGE	AVERAGE	RANGE
Alkalinity (mg/l)	160	150 - 180	110	84 - 130
Boron (µg/l)	180	180	153	120 - 220
Bromate (µg/l)	NA	NA	NA	NA
Calcium (mg/l)	66.7	63 - 71	56	27 - 76
Magnesium (mg/l)	15	14 - 16	22.3	11 - 30
N-Nitrosodimethylamine (ng/l)	NA	NA	2.03	ND - 5.1
pH (standard unit)	7.7	7.5 - 7.9	8.0	7.8 - 8.0
Potassium (mg/l)	3.7	3.6 - 3.7	4.1	2.6 - 5.3
Silica (mg/l)	28	28	NA	NA
Sodium (mg/l)	54	53 - 55	88.3	66 - 100
Total Hardness (mg/l)	230	210 - 240	230	120 - 310
Total Organic Carbon (mg/l)	1.1	1.1	2.1	1.2 - 2.6
Vanadium (µg/l)	ND	ND	4.2	ND - 6.7

ABBREVIATIONS

ABBREVIATIONS: NA = constituent not analyzed • NTU = nephelometric turbidity
uS/cm = Microsims per centimeter = a measure of electrical conductivity
ND = constituent not detected at the reporting limit
< = less than • SI = saturation index • pCi/l = picoCuries per liter
mg/l = milligrams per liter or parts per million . . . (equivalent to 1 drop in 42 gallons)
µg/l = micrograms per liter or parts per billion . . . (equivalent to 1 drop in 42,000 gallons)
ng/l = nanograms per liter or parts per trillion . . . (equivalent to 1 drop in 42,000,000 gallons)

FOOTNOTES

- Over 50 regulated and unregulated organic chemicals were analyzed. None were detected at or above the reporting limit in groundwater or surface water sources.
- Indicates dates sampled for groundwater sources only.
- California Public Health Goal (PHG). Other advisory levels listed in this column are federal Maximum Contaminant Level Goals (MCLGs).
- Combined Radium 226 + Radium 228 has a Maximum Contaminant Level (MCL) of 5 pCi/L.
- MCL compliance based on 4 consecutive quarters of sampling.
- Running annual average used to calculate average, range, and MCL compliance.
- Maximum Residual Disinfectant Level (MRDL)
- Maximum Residual Disinfectant Level Goal (MRDLG)
- 90th percentile from the most recent sampling at selected customer taps.
- Aluminum has primary and secondary standards.
- The secondary MCL for manganese was exceeded in one (1) out of two (2) wells in 2009. Manganese has been detected at elevated levels since 1995 and has been monitored monthly or quarterly since. Groundwater is blended with surface water before delivery to the customer, which dilutes the amount of manganese actually reaching the tap. Manganese samples taken weekly in the distribution system averaged well below regulatory limits. The manganese MCL is set to protect against unpleasant effects such as color, taste, odor, and staining of laundry/plumbing fixtures. A manganese secondary MCL exceedance does not pose a health risk.
- MWD started adding flouride at each treatment plant in the fall of 2007. MWD was in compliance with the provisions of the State's requirements.

DEFINITIONS

DEFINITIONS: **Maximum Contaminant Level (MCL):** The highest level of a contaminant that is allowed in drinking water. **Primary MCLs** are set as close to the PHGs (or MCLGs) as is economically and technologically feasible. **Secondary MCLs** are set to protect the odor, taste, and appearance of drinking water. **Maximum Contaminant Level Goal (MCLG):** The level of a contaminant in drinking water below which there is no known or expected risk to health. **MCLGs** are set by the U.S. Environmental Protection Agency. **Maximum Residual Disinfectant Level (MRDL):** The highest level of a disinfectant allowed in drinking water. There is convincing evidence that addition of a disinfectant is necessary for control of microbial contaminants. **Public Health Goal (PHG):** The level of a contaminant in drinking water below which there is no known or expected risk to health. **PHGs** are set by the California Environmental Protection Agency. **Treatment Technique (TT):** A required process intended to reduce the level of a contaminant in drinking water. **Regulatory Action Level (AL):** The concentration of a contaminant which, if exceeded, triggers treatment or other requirements that a water system must follow. **Primary Drinking Water Standard (PDWS):** MCLs and MRDLs for contaminants that affect health along with their monitoring and reporting requirements, and water treatment requirements.

ANEXO A

MAYWOOD MUTUAL WATER COMPANY #2

INFORMACIÓN ACERCA DEL SISTEMA DE AGUA

Maywood Mutual Water Company #2 sirve agua potable a partes de las ciudades de Maywood y Huntington Park. Aproximadamente 97% del sistema de distribución está ubicado en Maywood y el 3% restante está en Huntington Park. Un total de aproximadamente 1.179 acre-pies de agua fueron producidos por Maywood Mutual Water Company #2 en 2009, de los cuales aproximadamente 97% (1.144 acre-pies) de la producción total fue servida a la ciudad de Maywood, según Maywood Mutual Water Company #2. El sistema es una red con una zona de presión única. La siguiente tabla contiene las fuentes de suministro para Maywood Mutual Water Company #2.

Fuente	Capacidad (gpm)	Comentarios
Pozo de la avenida Maywood (pozo #1)	1.300	Bombea a un tanque de almacenamiento y luego es impulsada al sistema del distrito
Pozo de la calle 52 (pozo #2)	1.000	Bombea a un tanque de almacenamiento y luego es impulsada al sistema del distrito
CBMWD Válvula de alivio de la ave. Pine	2.500	Surte directamente al sistema de distribución

Maywood Mutual Water Company #2 también tiene una interconexión con Maywood Mutual Water Company #1 y Maywood Mutual Water Company #3 que puede utilizarse durante emergencias.

Maywood Mutual Water Company #2 está concluyendo la construcción y pruebas de un sistema de remoción de manganeso en la localidad de la calle 52. Una vez que el sistema haya sido probado y obtenga los permisos, el manganeso de este pozo estará por debajo de los niveles de la AB 890. La capacidad de la planta de tratamiento es de 1.100 gpm.

Maywood Mutual Water Company #2

-5207 Maywood Ave Pumphlot

One 70 ft. 1000K gal. tank
Two 70 ft. 370K gal. tank
One 150 hp. Deep Turbine Well, 1300 GPM
Two 15 hp. Fire Booster Pumps, 1600 GPM @ 20psi.
Three 40 hp. Boosters @ Hydropneumatic Pressure Station

-4421 52nd St. Pumphlot

One 36 ft. 190K gal. tank
One 50 hp. Booster Pump
One 125 hp. Deep Turbine Well Pump, 1000 GPM

-5315 Pine Ave. Pumphlot

Destroyed 10/2002 under LA County Health Dept. Permit

-5915 Pine Ave. Pressure Reducing Station

One 8" Hartman Sleeve Valve
One 12" Venturi Meter
One Flow Control and Totalizer Cabinet on west sidewalk

-Interconnection with Maywood Mutual Water Company # 1

Located at the Northwest Corner of Carmelita Ave. and Slauson Ave.
Two 6" Gate Valves, north and south sides of Slauson Ave.

-Interconnection with Maywood Mutual Water Company #3

Located at the Southwest Corner of 52nd St. and Cudahy
Two 6" Gate Valves, east and west sides of Cudahy

-Maywood Mutual Water Company # 2 Office

Located on 3521 E. Slauson Ave.

MMWC #2 Mains & Sizes

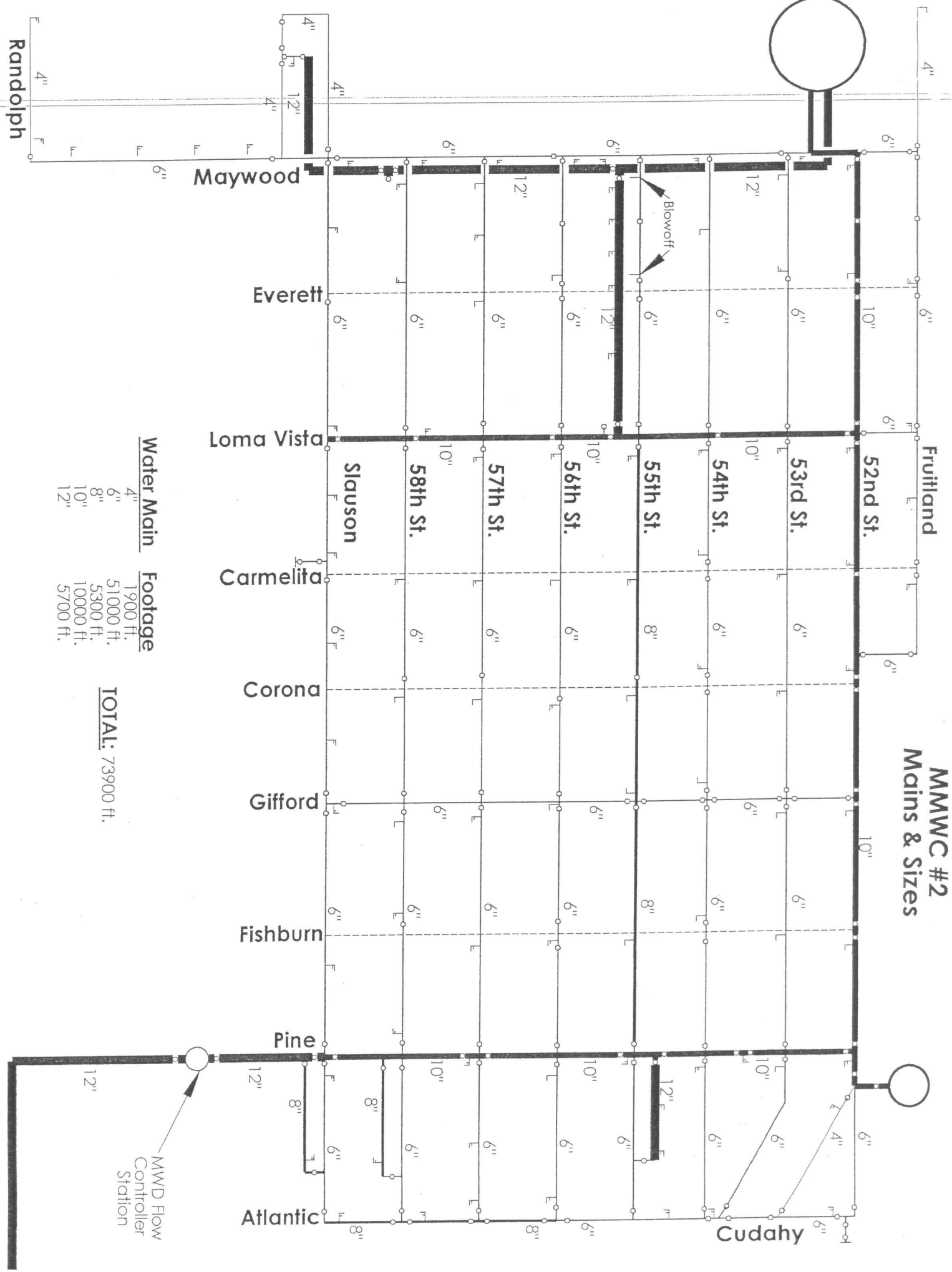

Water Main	Footage
4"	1900 ft.
6"	51000 ft.
8"	5300 ft.
10"	10000 ft.
12"	5700 ft.

TOTAL: 73900 ft.

MMWC #2 Valves & Hydrants

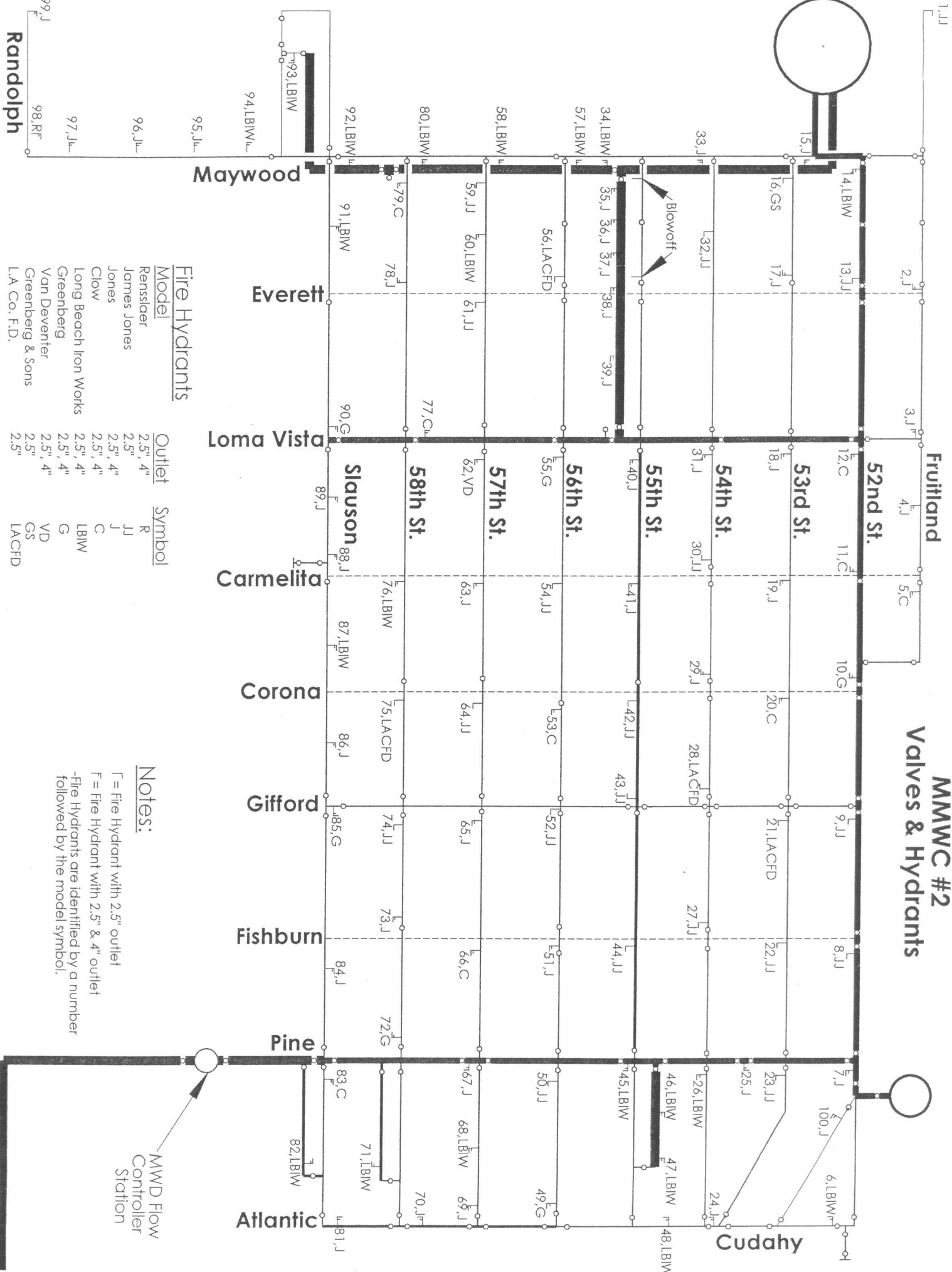

Model	Outlet	Symbol
Renssler	2.5" 4"	R
James Jones	2.5"	JJ
Jones	2.5" 4"	J
Clow	2.5" 4"	C
Long Beach Iron Works	2.5" 4"	LBW
Greenberg	2.5" 4"	G
Van Deventer	2.5" 4"	VD
Greenberg & Sons	2.5"	GS
L.A. Co. F.D.	2.5"	LACFD

Notes:
 F = Fire Hydrant with 2.5" outlet
 J = Fire Hydrant with 2.5" & 4" outlet
 -Fire Hydrants are identified by a number followed by the model symbol.

MWD Flow
Controller
Station

MAYWOOD MUTUAL WATER COMPANY NO. 2 2009 CONSUMER CONFIDENCE REPORT

Since 1991, California water utilities have been providing information on water served to its consumers. This report is a snapshot of the tap water quality that we provided last year. Included are details about where your water comes from, how it is tested, what is in it, and how it compares with state and federal limits. We strive to keep you informed about the quality of your water, and to provide a reliable and economic supply that meets all regulatory requirements.

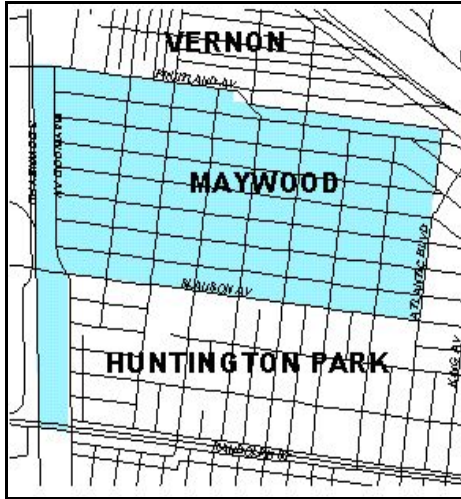

Where Does My Tap Water Come From?

Your tap water comes from local, deep groundwater wells that supply our service area shown on the adjacent map. The quality of groundwater delivered to your home is presented in this report.

How is My Drinking Water Tested?

Your drinking water is tested regularly for unsafe levels of chemicals, radioactivity and bacteria at the source and in the distribution system. We test weekly, monthly, quarterly, annually or less often depending on the substance. State and federal laws allow us to test some substances less than once per year because their levels do not change frequently. All water quality tests are conducted by specially trained technicians in state-certified laboratories.

What Are Drinking Water Standards?

The U.S Environmental Protection Agency (USEPA) limits the amount of certain substances allowed in tap water. In California, the State Department of Public Health (Department) regulates tap water quality by enforcing limits that are at least as stringent as the USEPA's. Historically, California limits are more stringent than the Federal ones.

There are two types of these limits, known as standards. Primary standards protect you from substances that could potentially affect your health. Secondary standards regulate substances that affect the aesthetic qualities of water. Regulations set a Maximum Contaminant Level (MCL) for each of the primary and secondary standards. The MCL is the highest level of a substance that is allowed in your drinking water.

Public Health Goals (PHGs) are set by the California Environmental Protection Agency. PHGs provide more information on the quality of drinking water to customers, and are similar to their federal counterparts, Maximum Contaminant Level Goals (MCLGs). PHGs and MCLGs are advisory levels that are nonenforceable. Both PHGs and MCLGs are concentrations of a substance below which there are no known or expected health risks.

How Do I Read the Water Quality Table?

Although we test for over 100 substances, regulations require us to report only those found in your water. The first column of the water quality table lists substances detected in your water. The next columns list the average concentration and range of concentrations found in your drinking water. Following are columns that list the MCL and PHG or MCLG, if appropriate. The last column describes the likely sources of these substances in drinking water.

To review the quality of your drinking water, compare the highest concentration and the MCL. Check for substances greater than the MCL. Exceedence of a primary MCL does not usually constitute an immediate health threat. Rather, it requires testing the source water more frequently for a short duration. If test results show that the water continues to exceed the MCL, the water must be treated to remove the substance, or the source must be removed from service.

Why Do I See So Much Coverage in the News About the Quality Of Tap Water?

The sources of drinking water (both tap water and bottled water) include rivers, lakes, streams, ponds, reservoirs, springs and wells. As water travels over the surface of the land or through the ground, it dissolves naturally occurring minerals and, in some cases, radioactive material, and can pick up substances resulting from the presence of animals or from human activity.

Contaminants that may be present in source water include:

- Microbial contaminants, including viruses and bacteria, that may come from sewage treatment plants, septic systems, agricultural livestock operations, and wildlife;

- Inorganic contaminants, such as salts and metals, that can be naturally-occurring or result from urban stormwater runoff, industrial or domestic wastewater discharges, oil and gas production, mining or farming;
- Pesticides and herbicides, that may come from a variety of sources such as agriculture, urban stormwater runoff, and residential uses;
- Organic chemical contaminants, including synthetic and volatile organic chemicals, that are byproducts of industrial processes and petroleum production, and can also come from gas stations, urban stormwater runoff, agricultural application, and septic systems;
- Radioactive contaminants, that can be naturally occurring or be the result of oil and gas production and mining activities.

In order to ensure that tap water is safe to drink, the USEPA and the Department prescribe regulations that limit the amount of certain contaminants in water provided by public water systems. Department regulations also establish limits for contaminants in bottled water that must provide the same protection for public health.

All drinking water, including bottled water, may reasonably be expected to contain at least small amounts of some contaminants. The presence of contaminants does not necessarily indicate that water poses a health risk. More information about contaminants and potential health effects can be obtained by calling the USEPA's Safe Drinking Water Hotline (1-800-426-4791). You can also get more information on tap water by logging on to these helpful web sites:

- www.epa.gov/OGWDW (USEPA's web site)
- www.cdph.ca.gov (Department of Public Health web site)

If present, elevated levels of lead can cause serious health problem, especially for pregnant women and young children. Lead in drinking water is primarily from materials and components associated with services lines and home plumbing. Maywood Mutual Water Company No. 2 is responsible for providing high quality drinking water, but cannot control the variety of materials used in plumbing components. When your water has been sitting for several hours, you can minimize the potential for lead exposure by flushing your tap for 30 seconds to 2 minutes before using water for drinking or cooking. If you are concerned about lead in your water, you may wish to have your water tested. Information on lead in drinking water, testing methods, and steps you can take to minimize exposure is available from the Safe Drinking Water Hotline or at <http://www.epa.gov/safewater/lead>.

Should I Take Additional Precautions?

Some people may be more vulnerable to contaminants in drinking water than the general population. Immunocompromised persons such as persons with cancer undergoing chemotherapy, persons who have undergone organ transplants, people with HIV/AIDS or other immune system disorders, some elderly, and infants can be particularly at risk from infections. These people should seek advice about drinking water from their health care providers. The USEPA/Centers for Disease Control guidelines on appropriate means to lessen the risk of infection of *Cryptosporidium* and other microbial contaminants are available from the USEPA's Safe Drinking Water Hotline (1-800-426-4791).

Source Water Assessment

Maywood Mutual Water Company No. 2 conducted an assessment of its groundwater supplies in 2003. Groundwater supplies are considered most vulnerable to electrical/electronic manufacturing, chemical/petroleum processing/storage, sewer collection systems, historic gas stations, military installations, metal plating/finishing/fabricating, automobile repair shops, fleet/truck/bus terminals, wood/pulp/paper processing and mills, and landfills/dumps. A copy of the approved assessment may be viewed at the water company office.

How Can I Participate in Decisions On Water Issues That Affect Me?

Shareholders are welcome to attend monthly Board of Directors meetings the third or fourth Tuesday of each month at 4:00 p.m. at 3521 E. Slauson Avenue, Maywood CA 90270. Please call the office at least one day prior to the meeting to be placed on the agenda.

How Do I Contact My Water Agency If I Have Any Questions About Water Quality?

If you have specific questions about your tap water quality, please contact Gustavo N. Villa at (323) 581-5816.

Some Helpful Water Conservation Tips

- Fix leaky faucets in your home – save up to 20 gallons every day for every leak stopped
- Save between 15 and 50 gallons each time by only washing full loads of laundry
- Adjust your sprinklers so that water lands on your lawn/garden, not the sidewalk/driveway – save 500 gallons per month
- Use organic mulch around plants to reduce evaporation – save hundreds of gallons a year

MAYWOOD MUTUAL WATER COMPANY No. 2 2009 CONSUMER CONFIDENCE REPORT

Results are from the most recent testing performed in accordance with state and federal drinking water regulations

PRIMARY STANDARDS MONITORED AT THE SOURCE - MANDATED FOR PUBLIC HEALTH

ORGANIC CHEMICALS (µg/l)	GROUNDWATER		PRIMARY MCL	MCLG or PHG	MAJOR SOURCES IN DRINKING WATER
	AVERAGE (a)	RANGE (a)			
INORGANICS Sampled from 2007 to 2009 (b)					
Aluminum (mg/l)	ND	ND	1	0.6 (c)	Erosion of natural deposits; residue from surface water treatment processes
Arsenic (µg/l)	ND	ND	10	0.004	Erosion of natural deposits; glass/electronics production wastes; runoff
Barium (mg/l)	ND	ND	1	2 (c)	Oil drilling waste and metal refinery discharge; erosion of natural deposits
Fluoride (mg/l)	0.37	0.34-0.4	2.0	1 (c)	Erosion of natural deposits, water additive that promotes strong teeth
Nitrate (mg/l as NO3)	1.8	ND - 7.1	45	45 (c)	Runoff and leaching from fertilizer user/septic tanks/sewage, natural erosion
Perchlorate (µg/l)	ND	ND	6	6	Industrial waste discharge
RADIOLOGICAL - (pCi/l) Analyzed 4 consecutive quarters every 4 years (results are from 2006 to 2009) (b)					
Gross Alpha	1.5	1.5	15 (e)	0	Erosion of natural deposits
Radium 226	NA	NA	5 (d)	0.05	Erosion of natural deposits
Radium 228	NA	NA		0.019	Erosion of natural deposits
Uranium	ND	ND	20 (e)	0.43 (c)	Erosion of natural deposits

PRIMARY STANDARDS MONITORED IN THE DISTRIBUTION SYSTEM - MANDATED FOR PUBLIC HEALTH

MICROBIALS	DISTRIBUTION SYSTEM		PRIMARY MCL	MCLG or PHG	Naturally present in the environment Human and animal fecal waste
	AVERAGE # POSITIVE	RANGE OF # POSITIVE			
Total Coliform Bacteria	0	0	< 1 positive	0	
Fecal Coliform and E.Coli Bacteria	0	0	0	0	
No. of Acute Violations	0	0	-	-	
DISTRIBUTION SYSTEM					
AVERAGE	RANGE		TT	-	Soil runoff
Turbidity (NTU)	0.1 - 1.5				
DISINFECTION BY-PRODUCTS (f)					
HIGHEST RUNNING ANNUAL AVERAGE		RANGE		PRIMARY MCL	MCLG or PHG
Total Trihalomethanes-TTHMs (µg/l)	20.7	17.4 - 26.9	80	-	By-product of drinking water chlorination
Halacetic Acids (µg/l)	3.6	3.1 - 3.9	60	-	By-product of drinking water disinfection
Total Chlorine Residual (mg/l)	0.74	0.24 - 1.98	4.0 (g)	4.0 (h)	Drinking water disinfectant added for treatment
AT THE TAP					
PHYSICAL CONSTITUENTS		DISTRIBUTION SYSTEM		PRIMARY MCL	MCLG or PHG
20 sites sampled in 2007		# OF SITES ABOVE THE AL			
Copper (mg/l)	0.17 (i)	0	1.3 AL	0.3 (c)	Internal corrosion of household plumbing, erosion of natural deposits
Lead (µg/l)	ND (i)	0	15 AL	2 (c)	Internal corrosion of household plumbing, industrial manufacturer discharges

SECONDARY STANDARDS MONITORED AT THE SOURCE-FOR AESTHETIC PURPOSES

Sampled from 2007-2009 (b)

	GROUNDWATER		SECONDARY	MCLG
	AVERAGE	RANGE	MCL	or PHG
Aggressiveness Index (corrosivity)	12	12	Non-corrosive	-
Aluminum (µg/l) (f)	ND	ND	200	600 (c)
Chloride (mg/l)	45.5	34-57	500	-
Color (color units)	ND	ND	15	-
Conductivity (µS/cm)	595	540-650	1,600	-
Iron (µg/l)	18.5	ND - 360	300	-
Langlier Index (corrosivity) (SI)	NA	NA	Non-corrosive	-
Manganese (µg/l)	63.5	ND - 150 (k)	50	-
Odor (threshold odor number)	ND	ND	3	-
Sulfate (mg/l)	74.5	70-79	500	-
Total Dissolved Solids (mg/l)	375	330-420	1,000	-
Turbidity (NTU)	0.12	ND-0.23	5	-

SECONDARY STANDARDS MONITORED IN THE DISTRIBUTION SYSTEM-FOR AESTHETIC PURPOSES

GENERAL PHYSICAL CONSTITUENTS	DISTRIBUTION SYSTEM		SECONDARY	MCLG
	AVERAGE	RANGE	MCL	or PHG
Color (color units)	6.4	<3 - 20	15	-
Odor (threshold odor number)	1	1	3	-

ADDITIONAL CHEMICALS OF INTEREST

Sampled from 2007 - 2009 (b)

GROUNDWATER	
AVERAGE	RANGE
Alkalinity (mg/l)	190.0
Boron (µg/l)	180-200
Bromate (µg/l)	NA
Calcium (mg/l)	NA
Magnesium (mg/l)	53.5
N-Nitrosodimethylamine (ng/l)	13.0
pH (standard unit)	7.9
Potassium (mg/l)	3.6
Sodium (mg/l)	3.3-3.9
Total Hardness (mg/l)	53.5
Vanadium (µg/l)	185.0
1,4-Dioxane (ug/l)	NA

ABBREVIATIONS

< = less than
SI = saturation index
ND = constituent not detected at the reporting limit
mg/l = milligrams per liter or parts per million (equivalent to 1 drop in 42 gallons)
ng/l = nanograms per liter or parts per trillion (equivalent to 1 drop in 42,000,000 gallons)

DEFINITIONS

Maximum Contaminant Level (MCL): The highest level of a contaminant that is allowed in drinking water. Primary MCLs are set as close to the PHGs (or MCLGs) as is economically and technologically feasible. Secondary MCLs are set to protect the odor, taste, and appearance of drinking water.
Maximum Contaminant Level Goal (MCLG): The level of a contaminant in drinking water below which there is no known or expected risk to health. MCLGs are set by the U.S. Environmental Protection Agency.
Maximum Residual Disinfectant Level (MRDL): The highest level of a disinfectant allowed in drinking water. There is convincing evidence that addition of a disinfectant is necessary for control of microbial contaminants.
Maximum Residual Disinfectant Level Goal (MRDLG): The level of a drinking water disinfectant below which there is no known or expected risk to health. MRDLGs do not reflect the benefits of the use of disinfectant to control microbial contaminants.
Public Health Goal (PHG): The level of a contaminant in drinking water below which there is no known or expected risk to health. PHGs are set by the California Environmental Protection Agency.
Treatment Technique (TT): A required process intended to reduce the level of a contaminant in drinking water.
Regulatory Action Level (AL): The concentration of a contaminant which, if exceeded, triggers treatment or other requirements that a water system must follow.
Primary Drinking Water Standard (PDWS): MCLs and MRDLs for contaminants that affect health along with their monitoring and reporting requirements, and water treatment requirements.
Secondary Water Standard (SDWS): MCLs and MRDLs for contaminants that affect the aesthetic qualities of water.

FOOTNOTES

(a) California Public Health Goal (PHG). Other advisory levels listed in this column are federal Maximum Contaminant Level Goals (MCLGs).
(b) Indicates dates sampled for groundwater sources only.
(c) California Public Health Goal (PHG). Other advisory levels listed in this column are federal Maximum Contaminant Level Goals (MCLGs).
(d) Combined Radium 226 + Radium 228 has a Maximum Contaminant Level (MCL) of 5 pCi/L.
(e) MCL compliance based on 4 consecutive quarters of sampling.
(f) Running annual average used to calculate average, range, and MCL compliance.
(g) Maximum Residual Disinfectant Level (MRDL)
(h) Maximum Residual Disinfectant Level Goal (MRDLG)
(i) 90th percentile from the most recent sampling at selected customer taps.
(j) Aluminum has primary and secondary standards.
(k) The secondary MCL for manganese was exceeded in two wells in 2009. Both wells have experienced manganese at elevated levels on a regular basis since 1990. Groundwater is blended with surface water before delivery to the customer, which dilutes the amount of manganese actually reaching the tap. The manganese secondary MCL is set to protect against unpleasant effects such as color, taste, odor, and staining of laundry/plumbing fixtures. A manganese secondary MCL exceedance does not pose a health risk.

LA COMPAÑÍA DE AGUA DE MAYWOOD MUTUAL No. 2

INFORME DE CONFIANZA DE CONSUMIDOR de 2009

Desde 1991, las agencias proveedoras de recursos hidráulicos de California han emitido información sobre el agua que se provee al consumidor. Este informe es una copia del informe sobre la calidad del agua potable que le proveímos el año pasado. Incluimos detalles sobre el origen del agua que toma, cómo se analiza, que contiene, y cómo se compara con los límites estatales y federales. Nos esforzamos por mantenerle informado sobre la calidad de su agua, y proveerle un abastecimiento confiable y económico que cumpla con todos los requisitos.

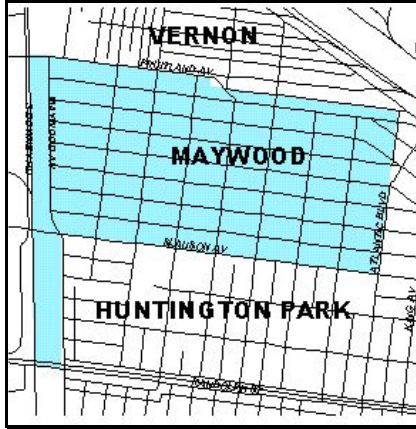

¿De Dónde Proviene el Agua que Tomo?

Su agua del grifo viene de pozos de agua subterránea locales, profundos que suministran nuestra área de servicio mostrada en el mapa adyacente. La calidad de agua subterránea entregada a su casa es presentada en este informe.

¿Cómo Se Analiza Mi Agua Potable?

El agua que toma se analiza regularmente para asegurarnos de que no halla niveles altos de sustancias químicas, de radioactividad o de bacteria en el sistema de distribución y en las tomas de servicios. Estos análisis se llevan a cabo semanal, mensual, trimestral, y anualmente o con más frecuencia, dependiendo de la sustancia analizada. Bajo las leyes estatales y federales, se nos permite analizar algunas sustancias menos frecuentemente que los periodos anuales porque los resultados no cambian.

¿Cuales Son Los Estándares del Agua Potable?

La Agencia federal de Protección al Medio Ambiente (USEPA) impone los límites de las cantidades de ciertos contaminantes en el agua potable. En California, el Ministerio de Asuntos Exteriores de la Seguridad Social Pública (Departamento) regula la calidad de agua del grifo haciendo cumplir límites que son al menos tan rigurosos como el USEPA'S. Historicamente, los estándares de California han sido más estrictos que los federales.

Hay dos tipos de límites conocidos como estándares. Los estándares primarios lo protegen de sustancias que potencialmente podrían afectar su salud. Las normas establecen los Niveles Contaminantes Máximos (MCL, en inglés) que se permite del contaminante primario o secundario en el agua de beber. Los abastecedores de agua deben asegurarse de que la calidad de esta cumpla con los Niveles Contaminantes Máximos (o MCLs, en inglés). No todas las sustancias tienen un Nivel Contaminante Máximo. El plomo y el cobre, por ejemplo, son regulados, por cierto nivel de acción. Si cualquier sustancia química sobrepasa el nivel de acción, se dará la necesidad de un proceso de tratamiento para rebajar los niveles en el agua de beber. Los abastecedores de agua deben cumplir con los Niveles Contaminantes Máximos para asegurar la calidad del agua.

Las Metas para la Salud Pública (MSP [o PHGs, en inglés]) son establecidas por la agencia estatal de California-EPA. Las PHGs proveen más información con respecto a la calidad del agua, y son similares a los reglamentos federales nombrados Metas para Los Niveles de Contaminante *Maximos* (MNCM [o MCLGs, en inglés]). Las PHGs y MCLGs son metas a nivel recomendable. Las PHG y MCLG son ambas definidas como los niveles de contaminantes en el agua potable por debajo de los niveles donde no se esperan riesgos a la salud y no enforzables. Ambos niveles PHG y MCLG son concentraciones de una sustancia en las que no hay riesgos a la salud aún conocidos.

¿Cómo Interpreto Mi Informe de Calidad del Agua?

Aunque analizamos más de 100 sustancias, las normas nos requirerem que reportemos solo aquellas que se encuentran en el agua. La primer columna en la tabla de la calidad de agua muestra la lista de las sustancias detectadas en el agua. La siguiente columna muestra la lista de la concentración promedio y el rango de concentraciones que se hallan encontrado en el agua que usted toma. En seguida están las listas de el MCL, el PHG y el MCLG, si estos son apropiados. La última columna describe las probables fuentes u origen de las sustancias detectadas en el agua potable.

Para revisar la calidad de su agua de beber, compare los valores por encima del promedio, mínimos y máximos y el Nivel Contaminante Máximo. Revise todos los químicos que se encuentran por encima del Nivel Contaminante Máximo. Si los químicos sobrepasan el Nivel Contaminante Máximo no significa que sea detrimental a la salud de inmediato. Más bien, se requiere que se realicen análisis más frecuentemente en el abastecimiento del agua por un corto período. Si los resultados muestran sobrepasar el MCL, el agua debe ser tratada para remover esa sustancia, o el abastecimiento de esta debe decomisionarse.

¿Por Qué Hay Tanta Publicidad Sobre La Calidad Del Agua Potable?

Las fuentes del agua potable (de ambas agua de la llave y agua embotellada) incluye ríos, lagos, arroyos, lagunas, embalses, manantiales, y pozos. Al pasar el agua por la superficie de los suelos o por la tierra, se disuelven minerales que ocurren al natural, y en algunas ocasiones, material radioactivo, al igual que pueden levantar sustancias generadas por la presencia de animales o por actividades humanas.

Entre los contaminantes que pueden existir en las fuentes de agua se incluyen:

- Contaminantes microbiales como los virus y la bacteria, los que pueden venir de las plantas de tratamiento de aguas negras, de los sistemas sépticos, de las operaciones de ganadería, y de la vida salvaje;
- Contaminantes inorgánicos, como las sales y los metales, los cuales pueden ocurrir naturalmente o como resultado del desagüe pluvial, industrial, o de alcantarillado, producción de gas natural y petróleo, minas y agricultura.
- Pesticidas y herbicidas, los cuales pueden venir de varias fuentes tales como la agricultura, del desagüe pluvial, y de usos residenciales;
- Contaminantes de otras sustancias químicas orgánicas, incluyendo químicos orgánicos volátiles y sintéticos que son productos de procesos industriales y de la producción de petróleo, y que pueden provenir de las estaciones de gasolina, desagües pluviales urbanos, y agricultura aplicación y de sistemas sépticos;
- Contaminantes radioactivos, los cuales pueden ocurrir naturalmente o que pueden ser resultados de las actividades de la producción de gas natural y minería.

Para asegurarse que el agua potable sea saludable, la USEPA y el Departamento impone reglamentos que limitan las cantidades de ciertos contaminantes en el agua que los sistemas públicos de agua proveen. Los reglamentos de Departamento también establecen límites de contaminantes en el agua embotellada la cual debe proveer la misma protección a la salud pública.

Toda el agua potable, incluyendo el agua embotellada, puede contener cantidades pequeñas de ciertos contaminantes. La presencia de contaminantes no necesariamente indica que haya algún riesgo de salud. Para más información acerca de contaminantes y riesgos a la salud favor de llamar a la USEPA encargada de proteger el agua potable al teléfono (1-800-426-4791). Usted puede obtener más información sobre el agua potable al conectarse al Internet en los siguientes domicilios:

- www.epa.gov/OGWDW (el sitio Web del USEPA) • www.cdph.ca.gov (sitio Web de Departamento de Salud Pública)

Si presente, los niveles elevados del plomo pueden causar el problema de salud serio, sobre todo para mujeres embarazadas y chiquitos. El plomo en el agua potable es principalmente de materiales y componentes asociados con líneas de servicios y a casa fontanería. Maywood Compañía de Echar agua Mutua el No 2 es responsable de proporcionar el agua potable de alta calidad, pero no puede controlar la variedad de materiales usados en la fontanería de componentes. Cuando su echar agua ha estado sentándose durante varias horas, usted puede minimizar el potencial para la exposición de plomo limpiando con agua su grifo durante 30 segundos a 2 minutos antes de usar el echar agua para beber o cocinarse. Si usted está preocupado por el plomo en su echar agua, usted puede desear hacer probar su echar agua. La información en el plomo en el agua potable, probando métodos, y pasos que usted puede tomar para minimizar la exposición está disponible de la Línea directa de Agua Potable Segura o en <http://www.epa.gov/safewater/lead>.

¿Debería Tomar Otras Precauciones?

Algunas personas pueden ser más vulnerables a los contaminantes en el agua potable que el público en general. Las personas que tienen problemas inmunológicos, o sea esas personas que estén en tratamiento por medio de quimioterapia cancerosa; personas que tienen órganos transplantados, o personas con SIDA o desórdenes inmunológicos, personas de edad avanzada, y los bebés que son particularmente susceptibles a ciertas infecciones. Estas personas deben de consultar a sus proveedores de salud médica. Las guías de la USEPA/Centros de Control de Enfermedades aconsejan cómo disminuir los riesgos para prevenir la infección de Cryptosporidium y otros contaminantes microbiales están disponibles por teléfono de la USEPA encargada de proteger el agua potable al teléfono (1-800-426-4791).

Valoración de su Abastecimiento de Agua

La compañía de agua de Maywood Mutual #2 condujo una valoración de su abastecimiento de aguas subterráneas en el 2003. El abastecimiento de aguas subterráneas es considerado mas vulnerable a la manufactura electrónica y eléctrica; a químicos, procesos petroleros, a sistemas de colección de alcantarillados; a estaciones de gasolina históricas; a instalaciones militares; al plateado, acabado, y fabricación de metal; a talleres automotrices; a flotas, camiones, y terminales de autobuses; a la elaboración y fabricación de madera, pasta, y papel; y a depósitos bajo tierra y basureros. Una copia de la valoración aprobada puede ser leer a la oficina a la 3521 E. Slauson Ave.

¿Cómo Puedo Participar en las Decisiones Sobre Asuntos Acerca del Agua Que Me Puedan Afectar ?

Los accionistas son bienvenidos asisten a reuniones de Junta directiva mensuales el tercer o cuarto martes de cada mes en 4:00 en 3521 E. Avenida de Slauson, Maywood CA 90270. Por favor llame la oficina al menos un día antes de la reunión para ser colocada por el orden del día.

¿Cómo Me Pongo En Contacto Con Mi Agencia del Agua Si Tengo Preguntas Sobre La Calidad Del Agua?

Si usted tiene preguntas específicas sobre la calidad del agua potable, por favor llame a Gustavo N. Villa (323) 581-5816.

Algunas extremidades provechosas de la conservación del agua

- Arreglar los grifos que gotean en su hogar - excepto hasta 20 galones cada día por cada detenido de fugas
- Guardar entre 15 y 50 galones por cada vez que el lavado sólo cargas completas de ropa
- Ajuste sus regaderas de modo que el agua caiga en su césped / jardín, no la acera / calzada - excepto 500 galones por mes
- Utilice pajote orgánico alrededor de las plantas para reducir la evaporación - guardar cientos de galones por año

MAYWOOD MUTUAL WATER COMPANY NO. 2
2009 CONSUMER CONFIDENCE REPORT

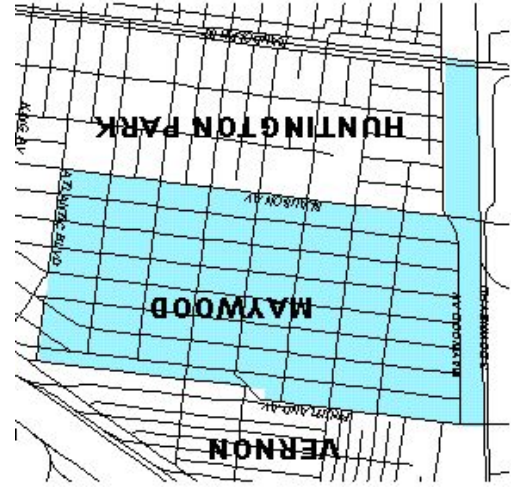

Este informe contiene información muy importante sobre su agua potable. Tradúzcalo o hable con alguien que lo entienda bien. Para obtener una copia en Español, llame a (323) 581-5816.

MAYWOOD MUTUAL WATER COMPANY NO. 2
3521 E. SLAUSON AVE
MAYWOOD, CA 90270

ANEXO A

MAYWOOD MUTUAL WATER COMPANY #3

INFORMACIÓN ACERCA DEL SISTEMA DE AGUA

Maywood Mutual Water Company #3 sirve a partes de las ciudades de Maywood, Bell, y Vernon (industrial). Un total de aproximadamente 1.502 acre-pies de agua fueron producidos por Maywood Mutual Water Company #3 en 2009, de los cuales aproximadamente 52% (772 acre-pies) del agua total vendida por Maywood Mutual Water Company #3 le fue suministrada a clientes en la ciudad de Maywood. La siguiente tabla contiene información acerca de las fuentes de suministro de Maywood Mutual Water Company #3.

Fuente	Capacidad (gpm)	Comentarios
Pozo <i>Prospect</i> (pozo #1)	750	Bombea a un tanque de almacenamiento y luego es impulsada al sistema del distrito
Pozo <i>Warehouse</i> (pozo #7)	1.000	Bombea a un tanque de almacenamiento y luego es impulsada al sistema del distrito
Pozo distrital (pozo #4)	1.300	Bombea a un tanque de almacenamiento y luego es impulsada al sistema del distrito

Maywood Mutual Water Company #3 también tiene conexiones de emergencia con Maywood Mutual Water Company #2 y Southern California Water Company.

2008/2009 Water Year

MAYWOOD MUTUAL WATER COMPANY No. 3

CITY/WATER UTILITY INFORMATION

CITY/WATER UTILITY	MAYWOOD MUTUAL WATER COMPANY No. 3 System # 19-086			
SERVICE AREA	City of Maywood, and City of Bell, small part of Vernon (industrial)			
AREA (SQUARE MILES)	<ONE Square Mile 19 miles of pipe 100,000 feet of service mains			
SERVICE AREA POPULATION	9,500	Average of 4.9 per household		Average useage 150 gpd per person
NUMBER OF CONNECTIONS	2023 total	1954 residential customers		
NUMBER OF CONNECTIONS ACTIVE	2004 total	1938 residential customers		
WATER RIGHTS	1407 A/F	Average years demand 1625 A/F		
Location and State ID#		Latitude		Longitude
Well #57 State #02S/12W-19C003S(New)	N	33.98876559	W	-118.177776981
Well #4 District State #02S/12W-19J02S	N	33.98028463	W	-118.170564025
Prospect Well State # 02S/12W-19M02S	N	33.97948985	W	-118.183579003

FACILITY

WBMWD METER CONNECTIONS	NUMBER	CAPACITY (GPM)	FEEDER
1. GARFIELD & RANDOLPH	WB31a	3,000	Middle (south)
TOTAL		3,000	

INTERCONNECTIONS/EMERGENCY CONNECTIONS

Description/Location	AGENCY	CAPACITY
1. Atlantic & 52nd street	Maywood Mutual Water Co. No. 2	System Pressure 6" main
2. Atlantic & Gage	So. Calif Water Company	System Pressure 6" main
TOTAL		1,000 (GPM) each

BOOSTER STATIONS

Description/Location	Capacity (GPM)	Discharge	Suction	# of Pumps	Standby power
1. District 4-District & Randolph	2150	x	Res/Well	3	250KW Gen.
2. Prospect 1-Prospect & Filmore	1650	x	Res/Well	3	N
3. 57th street 3 warehouse	1100	x	Res. Only	2	N
TOTAL	4900	May-00		8	May-00

RESERVOIRS

Description/Location	Storage (MG)	Source	Average Fill	Standby power
1. District 4	4	Well/System	2.6	N
2. Prospect 1	0.5	Well/System	0.3	N
3. 57th street 3 warehouse	0.175	Well/System	0.12	N
4. Elevated Tank 5519 District	0.2	System	0.125	N
TOTAL	4.875		3.145	

WELLS

Description/Location	Capacity (GPM)	Previous years Prod.	Discharge	Treatment	Standby power
1. District 4	1360	479 A/F	Res/System	Hypo	250KW Gen.
2. Prospect 1	400	479 A/F	Res/System	Hypo	N
3. 57th street 7 warehouse	1113	493 A/F	Res. Only	Hypo	N
4. MWD Connection/8" pressure valve	2000	0 A/F	System/Res	Clorimine	Gravity feed
TOTAL	4873	1451 A/F			

MWD Connection 80-160psi 2000 (GPM)
 12" MWD Main to our 8" System 6" Reducing Clay Valve adjustable from 30psi-100psi

325,851 GALLONS/A/F
 7.480509642 GALLONS/C/F
 43,560 C/F/A/F
 748.0509642 GALLONS/1C

PRESSURE ZONES

Number of Zones ONE 52-58psi

2009-2010

	January 1/1/2009	February 2/1/2009	March 3/1/2009	April 4/1/2009	May 5/1/2009	June 6/1/2009	July 7/1/2009	August 8/1/2009	September 9/1/2009	October 10/1/2009	November 11/1/2009	December 12/1/2009
GALLONS												
Plant 1 Prospect												Motor Blown Out
0	8480190	10967050	13718800	16203520	18911500	21312940	23895250	27241890	30508850	33883210	37041530	37633320
	2571700	2486860	2751750	2484720	2707980	2401440	2582310	3346640	3266960	3374360	3158320	591790
ACRE FEET	59.0381	57.0904	63.1715	57.0413	62.1667	55.1295	59.2817	76.8283	74.9991	77.4646	72.5051	13.5856
ELECTRIC USED	6884/528	7394/510	7955/561	8468/513	9033/545	9536/503	10078/542	10781/543	11465/684	12172/708	12834/662	12955/121
Hours per Acre Foot run/time	8.94 HP A/F	8.93 HP A/F	8.07 HP A/F	8.94 HP A/F	8.20 HP A/F	9.25 HP A/F	8.60 HP A/F	6.64 HP A/F	6.80 HP A/F	9.14 HP A/F	9.14 HP A/F	9.14 HP A/F
	13727 741	14441 714	15230 789	15946 716	16734 788	17437 703	18191 754	19163 972	20112 949	21097 985	22021 924	22195 174
KWH-A/F Average 7.48	NEW METER 12.55	NEW METER 12.51	NEW METER 12.49	NEW METER 12.55	NEW METER 12.68	NEW METER 12.75	NEW METER 12.72	NEW METER 12.65	NEW METER 12.65	NEW METER 12.72	NEW METER 12.74	NEW METER 12.81
Year to date amount	434.80 A/F	491.89 A/F	555.06 A/F	612.10 A/F	674.27 A/F	729.40 A/F	59.28 A/F	136.11 A/F	211.11 A/F	288.57 A/F	361.08 A/F	374.66 A/F
GALLONS												
Plant 3 W/House Well 7												
	16425530	17785940	19250550	21043440	22902460	24826560	26779900	28334860	29880980	31275410	32471360	34292990
	1354430	1360410	1464610	1792890	1859020	1924100	1953340	1554960	1546120	1394430	1195950	1821630
	31.0934	31.2307	33.6228	41.1591	42.6772	44.1713	44.8425	35.6970	35.4940	32.0117	27.4552	41.8189
ELECTRIC USED	2619/186 ⁴⁸⁸	2806/187 ⁴⁸⁹	3007/201 ⁵²⁷	3257/250 ⁵⁸⁷	3523/266 ⁶⁸⁵	3802/279 ⁷¹¹	4087/285 ⁷²⁴	4315/228 ⁵⁷⁵	4546/231 ⁵⁷⁵	4755/209 ⁵²³	4935/180 ⁴⁴⁵	5208/273 ⁶⁶⁵
Hours per Acre Foot run/time	5.98 HP A/F	5.99 HP A/F	5.56 HP A/F	4.54 HP A/F	4.38 HP A/F	4.23 HP A/F	4.17 HP A/F	5.24 HP A/F	5.27 HP A/F	6.53 HP A/F	6.53 HP A/F	6.53 HP A/F
0												
KWH-A/F Average 8.97												
Year to date amount	325.93 A/F	366.69 A/F	407.45 A/F	448.21 A/F	488.97 A/F	529.73 A/F	44.84 A/F	85.60 A/F	126.36 A/F	167.12 A/F	207.88 A/F	248.64 A/F
Prospect	50.16%	52.19%	52.13%	45.48%	45.40%	44.43%	42.52%	53.48%	55.41%	61.04%	62.11%	12.85%
Warehouse	26.42%	28.55%	27.75%	32.82%	31.17%	35.60%	32.16%	24.85%	26.22%	25.23%	23.52%	39.56%
District	23.41%	19.25%	20.13%	21.70%	23.42%	19.96%	25.32%	21.67%	18.37%	13.74%	14.35%	47.59%
Warehouse & District Total												
Plant 4 District	Rollover	Rollover	Rollover	Rollover	Rollover	Rollover	Rollover					
	102880500	103797700	104860200	106045600	107442600	108521600	110059600	111415400	112498200	113257500	113987400	116179100
	1200300	917200	1062500	1185400	1397000	1079000	1538000	1355800	1082800	759300	729900	2191700
	27.5551	21.0560	24.3916	27.2130	32.0707	24.7704	35.3076	31.1249	24.8577	17.4311	16.7562	50.3145
ELECTRIC USED	1925/212	2024/99	2140/116	2271/131	2427/156	2549/122	2724/175	2879/155	3004/125	3092/88	3177/85	3428/251
Hours per Acre Foot run/time	7.69 HP A/F	4.70 HP A/F	4.76 HP A/F	4.81 HP A/F	4.86 HP A/F	4.93 HP A/F	3.46 HP A/F	3.92 HP A/F	4.91 HP A/F	5.05 HP A/F	5.05 HP A/F	5.05 HP A/F
	2160	2339	2545	2777	3053	3270	3579	3852	4072	4229	4379	4819
	234	179	206	232	276	217	309	273	220	157	150	440
KWH-A/F Average 8.18	8.49	8.50	8.45	8.53	8.61	8.76	8.75	8.77	8.85	9.01	8.95	8.74
Year to date amount	245.77 A/F	266.82 A/F	291.21 A/F	318.43 A/F	350.50 A/F	375.27 A/F	35.31 A/F	66.43 A/F	91.29 A/F	108.72 A/F	125.48 A/F	175.79 A/F
ALL WELLS /MONTH	117.69 A/F	109.38 A/F	121.18 A/F	125.41 A/F	136.92 A/F	124.07 A/F	139.43 A/F	143.65 A/F	135.35 A/F	126.90 A/F	116.73 A/F	105.72 A/F
MWD purchased	0.0 A/F	0.0 A/F	0.0 A/F	0.0 A/F	0.0 A/F	0.0 A/F	0.0 A/F	0.0 A/F	0.0 A/F	0.0 A/F	0.0 A/F	0.0 A/F

577.23%	48.10%
353.85%	29.49%
268.92%	22.41%

Location and State ID#		Latitude		Longitude
Well #57 State #02S/12W-19C02S	N	33.98876559	W	-118.177776981
Well #4 District State #02S/12W-19J02S	N	33.98028463	W	-118.170564025
Prospect Well State # 02S/12W-19M02S	N	33.97948985	W	-118.183579003

WELLS

Description/Location	Capacity (GPM)	Previous years Prod.	Discharge	Treatment	Standby power
1. District 4 Depth 980 feet Water lubricating 100HP	1400	479 A/F Address: 6159 District Ave. Maywood, CA Perforations start 610'	Res/System	Hypo	250KW Gen.
2. Prospect 1 Depth 1333 feet Water lubricating 100HP	400	479 A/F Address: 6253 Prospect Bell, CA Perforations start 350"	Res/System	Hypo	N
3. 57th street 7 warehouse Depth 800 feet Water lubricating 100HP	1200	493 A/F Address: 4809 57th Street Maywood, CA Perforations start 635"	Res. Only	Hypo	N

Maywood Mutual Water Company No. 3

- Pump lots 1,2,3 & 4
- Wells "3"
- Storage Tanks "4" plus Elevated Tank
- Sample Points Bac-T & General Physical "4"
- Additional sample Points
- Chlorine & Hydrants
- Boosters & Water Mains
- Inter Connections Maywood 2 & So. Calif.
- Future Hydrants Locations

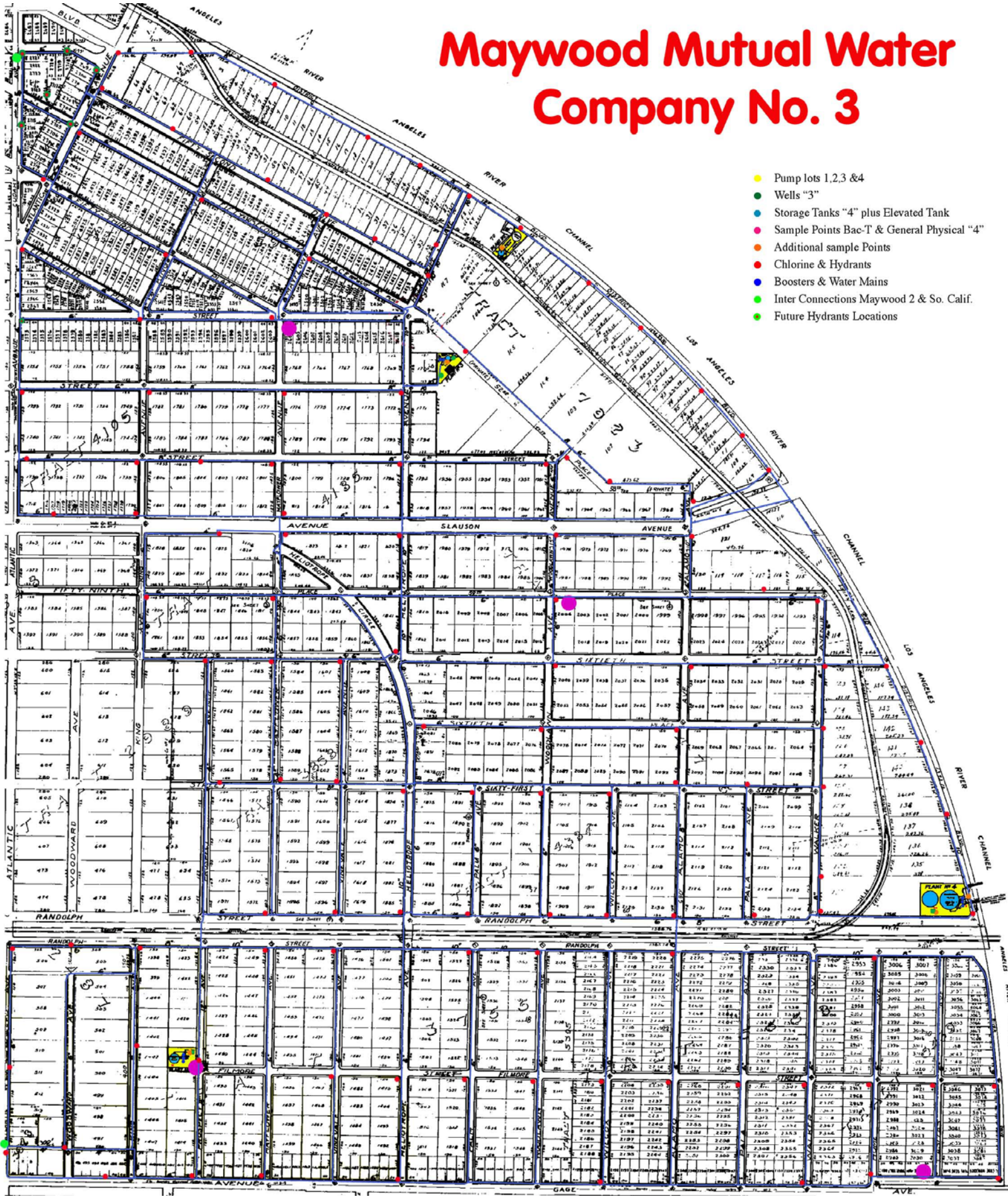



Este informe contiene información muy importante sobre su agua potable. Tradúzcalo o hable con alguien que lo entienda bien. Para obtener una copia en Español, llame a (323) 560-3657.

MAYWOOD MUTUAL WATER COMPANY NUMBER 3
6151 HELIOTROPE AVENUE
MAYWOOD, CA 90270

MAYWOOD MUTUAL WATER COMPANY NUMBER 3 2009 CONSUMER CONFIDENCE REPORT

Since 1991, California water utilities have been providing information on water served to its consumers. This report is a snapshot of the tap water quality that we provided last year. Included are details about where your water comes from, how it is tested, what is in it, and how it compares with state and federal limits. We strive to keep you informed about the quality of your water, and to provide a reliable and economic supply that meets all regulatory requirements.

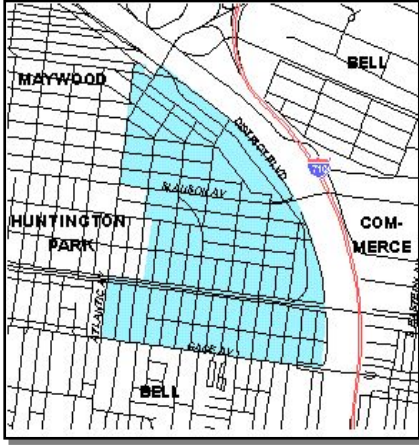

Where Does My Tap Water Come From?

Your tap water comes from local, deep groundwater wells that supply our service area shown on the adjacent map. The quality of groundwater delivered to your home is presented in this report.

How is My Drinking Water Tested?

Your drinking water is tested regularly for unsafe levels of chemicals, radioactivity and bacteria at the source and in the distribution system. We test weekly, monthly, quarterly, annually or less often depending on the substance. State and federal laws allow us to test some substances less than once per year because their levels do not change frequently. All water quality tests are conducted by specially trained technicians in state-certified laboratories.

What Are Drinking Water Standards?

The U.S Environmental Protection Agency (USEPA) limits the amount of certain substances allowed in tap water. In California, the State Department of Public Health (CDPH) regulates tap water quality by enforcing limits that are at least as stringent as the USEPA's. Historically, California limits are more stringent than the Federal ones.

There are two types of these limits, known as standards. Primary standards protect you from substances that could potentially affect your health. Secondary standards regulate substances that affect the aesthetic qualities of water. Regulations set a Maximum Contaminant Level (MCL) for each of the primary and secondary standards. The MCL is the highest level of a substance that is allowed in your drinking water.

Public Health Goals (PHGs) are set by the California Environmental Protection Agency. PHGs provide more information on the quality of drinking water to customers, and are similar to their federal counterparts, Maximum Contaminant Level Goals (MCLGs). PHGs and MCLGs are advisory levels that are nonenforceable. Both PHGs and MCLGs are concentrations of a substance below which there are no known or expected health risks.

How Do I Read the Water Quality Table?

Although we test for over 100 substances, regulations require us to report only those found in your water. The first column of the water quality table lists substances detected in your water. The next columns list the average concentration and range of concentrations found in your drinking water. Following are columns that list the MCL and PHG or MCLG, if appropriate. The last column describes the likely sources of these substances in drinking water.

To review the quality of your drinking water, compare the highest concentration and the MCL. Check for substances greater than the MCL. Exceedence of a primary MCL does not usually constitute an immediate health threat. Rather, it requires testing the source water more frequently for a short duration. If test results show that the water continues to exceed the MCL, the water must be treated to remove the substance, or the source must be removed from service.

Why Do I See So Much Coverage in the News About the Quality Of Tap Water?

The sources of drinking water (both tap water and bottled water) include rivers, lakes, streams, ponds, reservoirs, springs and wells. As water travels over the surface of the land or through the ground, it dissolves naturally occurring minerals and, in some cases, radioactive material, and can pick up substances resulting from the presence of animals or from human activity.

Contaminants that may be present in source water include:

- Microbial contaminants, including viruses and bacteria, that may come from sewage treatment plants, septic systems, agricultural livestock operations, and wildlife;
- Inorganic contaminants, such as salts and metals, that can be naturally-occurring or result from urban stormwater runoff, industrial or domestic wastewater discharges, oil and gas production, mining or farming;

- Pesticides and herbicides, which may come from a variety of sources such as agriculture, urban stormwater runoff, and residential uses;
- Organic chemical contaminants, including synthetic and volatile organic chemicals, that are by-products of industrial processes and petroleum production, and can also come from gas stations, urban stormwater runoff, agricultural application, and septic systems;
- Radioactive contaminants, which can be naturally occurring or be the result of oil and gas production and mining activities.

In order to ensure that tap water is safe to drink, the USEPA and the Department prescribe regulations that limit the amount of certain contaminants in water provided by public water systems. Department regulations also establish limits for contaminants in bottled water that must provide the same protection for public health.

All drinking water, including bottled water, may reasonably be expected to contain at least small amounts of some contaminants. The presence of contaminants does not necessarily indicate that water poses a health risk. More information about contaminants and potential health effects can be obtained by calling the USEPA's Safe Drinking Water Hotline (1-800-426-4791). You can also get more information on tap water by logging on to these helpful web sites:

- www.epa.gov/OGWDW (USEPA's web site)
- www.cdph.ca.gov (CDPH web site)

If present, elevated levels of lead can cause serious health problem, especially for pregnant women and young children. Lead in drinking water is primarily from materials and components associated with services lines and home plumbing. Maywood Mutual Water Company No. 3 is responsible for providing high quality drinking water, but cannot control the variety of materials used in plumbing components. When your water has been sitting for several hours, you can minimize the potential for lead exposure by flushing your tap for 30 seconds to 2 minutes before using water for drinking or cooking. If you are concerned about lead in your water, you may wish to have your water tested. Information on lead in drinking water, testing methods, and steps you can take to minimize exposure is available from the Safe Drinking Water Hotline or at <http://www.epa.gov/safewater/lead>.

Should I Take Additional Precautions?

Some people may be more vulnerable to contaminants in drinking water than the general population. Immunocompromised persons such as persons with cancer undergoing chemotherapy, persons who have undergone organ transplants, people with HIV/AIDS or other immune system disorders, some elderly, and infants can be particularly at risk from infections. These people should seek advice about drinking water from their health care providers. The USEPA/Centers for Disease Control guidelines on appropriate means to lessen the risk of infection of *Cryptosporidium* and other microbial contaminants are available from the USEPA's Safe Drinking Water Hotline (1-800-426-4791).

Source Water Assessment

Maywood Mutual Water Company No. 3 conducted an assessment of its groundwater supplies in 2001. Groundwater supplies are considered most vulnerable to chemical/petroleum processing/storage, chemical/petroleum pipelines, metal plating/finishing/fabricating, plastics/synthetics producers, parks, known contaminant plumes, confirmed leaking underground storage tanks, automobile body shops, automobile repair shops, electrical/electronic manufacturing, machine shops, photo processing/printing, furniture repair/manufacturing, home manufacturing, hardware/lumber/parts stores, parking lots/malls with more than 50 spaces, freeways/state highways, railroads, roads/streets, monitoring wells/test holes, automobile gas stations, high density housing (> 1 house/0.5 acre), medical/dental offices/clinics, apartments and condominiums, wood preserving/treating, and wood/pulp/paper processing and mills. A copy of the approved assessment may be obtained by contacting Mr. Robert Rohlf at (323) 560-3657.

How Can I Participate in Decisions On Water Issues That Affect Me?

Shareholders are welcome to attend the Board meetings held the last Tuesday of each month at 4:30 pm at 6151 Heliotrope Ave. Maywood, CA 90270.

How Do I Contact My Water Agency If I Have Any Questions About Water Quality?

If you have specific questions about your tap water quality, please contact Mr. Robert Rohlf at (323) 560-3657.

Some Helpful Water Conservation Tips

- Fix leaky faucets in your home – save up to 20 gallons every day for every leak stopped
- Save between 15 and 50 gallons each time by only washing full loads of laundry
- Adjust your sprinklers so that water lands on your lawn/garden, not the sidewalk/driveway – save 500 gallons per month
- Use organic mulch around plants to reduce evaporation – save hundreds of gallons a year
- Use a water-efficient showerhead. They're inexpensive, easy to install, and can save you up to 750 gallons a month.

MAYWOOD MUTUAL WATER COMPANY NUMBER 3 2009 CONSUMER CONFIDENCE REPORT

Results are from the most recent testing performed in accordance with state and federal drinking water regulations

PRIMARY STANDARDS MONITORED AT THE SOURCE-MANDATED FOR PUBLIC HEALTH

ORGANIC CHEMICALS (g/l)	GROUNDWATER		PRIMARY MCL	MCLG or PHG	MAJOR SOURCES IN DRINKING WATER
	AVERAGE	RANGE			
Tetrachloroethylene (PCE)	ND	ND	5	0.06 (a)	Discharge from factories, dry cleaners, and auto shops (metal degreaser)
Trichloroethylene (TCE)	2.4	ND-4.2	5	1.7 (a)	Discharge from metal degreasing sites and other factories

INORGANICS Sampled in 2007 To 2009 (b)					
Aluminum (mg/l)	ND	ND	1	0.6 (a)	Erosion of natural deposits; residue from surface water treatment processes
Arsenic (g/l)	ND	ND	10	0.004	Erosion of natural deposits; glass/electronics production wastes; runoff
Barium (mg/l)	ND	ND	1	2 (a)	Oil drilling waste and metal refinery discharge; erosion of natural deposits
Fluoride (mg/l)	0.33	0.26-0.39	2.0	1 (a)	Erosion of natural deposits, water additive that promotes strong teeth
Nitrate (mg/l as NO3)	8.7	ND-14	45	45 (a)	Runoff and leaching from fertilizer use/septic tanks/sewage, natural erosion

RADIOLOGICAL - (pCi/l) Analyzed 4 consecutive quarters every 4 years (results are from 2006 to 2009) (b)					
Gross Alpha (c)	1.37	ND-4.1	15 (d)	0	Erosion of natural deposits
Gross Beta	NA	NA	50 (d)	0	Decay of natural and man-made deposits
Radium 226	NA	NA		0.05	Erosion of natural deposits
Radium 228	ND	ND	5 (e)	0.019	Erosion of natural deposits
Uranium	0.7	ND-2.8	20 (d)	0.43 (a)	Erosion of natural deposits

PRIMARY STANDARDS MONITORED IN THE DISTRIBUTION SYSTEM - MANDATED FOR PUBLIC HEALTH

MICROBIALS	DISTRIBUTION SYSTEM		PRIMARY MCL	MCLG or PHG	
	AVERAGE # POSITIVE	RANGE OF # POSITIVE			
Total Coliform Bacteria	0	0	< 1 positive	0	Naturally present in the environment
Fecal Coliform and E.Coli Bacteria	0	0	0	0	Human and animal fecal waste
No. of Acute Violations	0	0	-	-	

MICROBIALS	DISTRIBUTION SYSTEM		PRIMARY MCL	MCLG or PHG	
	AVERAGE	RANGE			
Turbidity (NTU)	0.2	<1 - 0.7	TT	-	Soil runoff

DISINFECTION BY-PRODUCTS AND DISINFECTION RESIDUALS (f)	DISTRIBUTION SYSTEM		PRIMARY MCL	MCLG or PHG	
	AVERAGE	RANGE			
Total Trihalomethanes-TTHMS (g/l)	25.2	ND-69.2	80	-	By-product of drinking water disinfection.
Haloacetic Acids - HAAs (g/l)	4.6	ND-16.2	60	-	By-product of drinking water disinfection
Total Chlorine Residual (mg/l)	0.9	0.5-1.2	4.0 (g)	4.0 (h)	Drinking water disinfectant added for treatment

AT THE TAP PHYSICAL CONSTITUENTS 20 sites sampled in 2007	DISTRIBUTION SYSTEM		PRIMARY MCL	MCLG or PHG	
	90%ile	# OF SITES ABOVE THE AL			
Copper (mg/l)	ND (i)	0	1.3 AL	0.17 (a)	Internal corrosion of household plumbing, erosion of natural deposits
Lead (g/l)	ND (i)	0	15 AL	2 (a)	Internal corrosion of household plumbing, industrial manufacturer discharges

SECONDARY STANDARDS MONITORED AT THE SOURCE-FOR AESTHETIC PURPOSES

Sampled in 2007-2009 (b)

	GROUNDWATER		SECONDARY MCL	MCLG or PHG	
	AVERAGE	RANGE			
Aggressiveness Index (corrosivity)	13	13	Non-corrosive	-	Natural/industrially-influenced balance of hydrogen/carbon/oxygen in water
Aluminum (g/l) (i)	ND	ND	200	600 (a)	Erosion of natural deposits, surface water treatment process residue
Chloride (mg/l)	56	52-61	500	-	Runoff/leaching from natural deposits, seawater influence
Color (color units)	5	ND-15	15	-	Naturally-occurring organic materials
Conductivity (uS/cm)	696.7	580-780	1,600	-	Substances that form ions when in water, seawater influence
Iron (ug/l)	ND	ND	300	-	Leaching from natural deposits
Manganese (g/l)	8.7	ND-26	50	-	Leaching from natural deposits
Odor (threshold odor number)	ND	ND	3	-	Naturally-occurring organic materials
Sulfate (mg/l)	102.7	48-140	500	-	Runoff/leaching from natural deposits, industrial wastes
Total Dissolved Solids (mg/l)	450	370-500	1,000	-	Runoff/leaching from natural deposits
Turbidity (NTU)	0.19	ND-0.52	5	-	Soil runoff

SECONDARY STANDARDS MONITORED IN THE DISTRIBUTION SYSTEM-FOR AESTHETIC PURPOSES

GENERAL PHYSICAL CONSTITUENTS	DISTRIBUTION SYSTEM		SECONDARY MCL	MCLG or PHG	
	AVERAGE	RANGE			
Color (color units)	<3	<3	15	-	Naturally-occurring organic materials
Odor (threshold odor number)	1	1.0-2.0	3	-	Naturally-occurring organic materials

ADDITIONAL CHEMICALS OF INTEREST

Sampled in 2007-2009 (b)

	GROUNDWATER	
	AVERAGE	RANGE
Alkalinity (mg/l)	180	170-200
Boron (g/l)	NA	NA
Bromate (g/l)	NA	NA
Calcium (mg/l)	66	46-76
Magnesium (mg/l)	17	12-20
N-Nitrosodimethylamine (ng/l)	NA	NA
Perchlorate (g/l)	0.43	ND-5.7
pH (standard unit)	8.2	8.1-8.3
Potassium (mg/l)	3.2	3.1-3.2
Sodium (mg/l)	59	48-70
Total Hardness (mg/l)	233	160-270
Total Organic Carbon (mg/l)	NA	NA
Vanadium (g/l)	NA	NA

FOOTNOTES

- (a) California Public Health Goal (PHG). Other advisory levels listed in this column are federal Maximum Contaminant Level Goals (MCLGs).
- (b) Indicates dates sampled for groundwater sources only.
- (c) Gross alpha standard also includes Radium-226 standard.
- (d) MCL compliance based on 4 consecutive quarters of sampling.
- (e) Combined Radium 226 + Radium 228 has a Maximum Contaminant Level (MCL) of 5 pCi/L.
- (f) Running annual average used to calculate average, range, and MCL compliance.
- (g) Maximum Residual Disinfectant Level (MRDL)
- (h) Maximum Residual Disinfectant Level Goal (MRDLG)
- (i) 90th percentile from the most recent sampling at selected customer taps.
- (j) Aluminum has primary and secondary standards.

ABBREVIATIONS

- < = less than
- mg/l = milligrams per liter or parts per million (equivalent to 1 drop in 42 gallons)
- NA = constituent not analyzed
- ND = constituent not detected at the reporting limit
- ng/l = nanograms per liter or parts per trillion (equivalent to 1 drop in 42,000,000 gallons)
- g/l = micrograms per liter or parts per billion (equivalent to 1 drop in 42,000 gallons)

NTU = nephelometric turbidity units
pCi/l = picoCuries per liter
SI = saturation index
uS/cm = microSiemens per centimeter

DEFINITIONS

Maximum Contaminant Level (MCL): The highest level of a contaminant that is allowed in drinking water. Primary MCLs are set as close to the PHGs (or MCLGs) as is economically and technologically feasible. Secondary MCLs are set to protect the odor, taste, and appearance of drinking water.

Maximum Contaminant Level Goal (MCLG): The level of a contaminant in drinking water below which there is no known or expected risk to health. MCLGs are set by the U.S. Environmental Protection Agency.

Maximum Residual Disinfectant Level (MRDL): The level of a disinfectant added for water treatment that may not be exceeded at the consumer's tap.

Maximum Residual Disinfectant Level Goal (MRDLG): The level of a disinfectant added for water treatment below which there is no known or expected risk to health. MRDLGs are set by the U.S. Environmental Protection Agency.

Public Health Goal (PHG): The level of a contaminant in drinking water below which there is no known or expected risk to health. PHGs are set by the California Environmental Protection Agency.

Treatment Technique (TT): A required process intended to reduce the level of a contaminant in drinking water.

Regulatory Action Level (AL): The concentration of a contaminant which, if exceeded, triggers treatment or other requirements that a water system must follow.

Primary Drinking Water Standard (PDWS): MCLs and MRDLs for contaminants that affect health along with their monitoring and reporting requirements, and water treatment requirements.

Secondary Water Standard (SDWS): MCLs and MRDLs for contaminants that affect the aesthetic qualities of water.

LA COMPAÑÍA DE AGUA DE MAYWOOD MUTUAL NÚMERO 3

INFORME DE CONFIANZA DE CONSUMIDOR de 2009

Desde 1991, las agencias proveedoras de recursos hidráulicos de California han emitido información sobre el agua que se provee al consumidor. Este informe es una copia del informe sobre la calidad del agua potable que le proveímos el año pasado. Incluimos detalles sobre el origen del agua que toma, cómo se analiza, que contiene, y cómo se compara con los límites estatales y federales. Nos esforzamos por mantenerle informado sobre la calidad de su agua, y proveerle un abastecimiento confiable y económico que cumpla con todos los requisitos.

¿De Dónde Proviene el Agua que Tomo?

Su agua del grifo viene de pozos de agua subterránea locales, profundos que suministran nuestra área de servicio mostrada en el mapa adyacente. La calidad de agua subterránea entregada a su casa es presentada en este informe.

¿Cómo Se Analiza Mi Agua Potable?

El agua que toma se analiza regularmente para asegurarnos de que no halla niveles altos de sustancias químicas, de radioactividad o de bacteria en el sistema de distribución y en las tomas de servicios. Estos análisis se llevan a cabo semanal, mensual, trimestral, y anualmente o con más frecuencia, dependiendo de la sustancia analizada. Bajo las leyes estatales y federales, se nos permite analizar algunas sustancias menos frecuentemente que los periodos anuales porque los resultados no cambian.

¿Cuales Son Los Estándares del Agua Potable?

La Agencia federal de Protección al Medio Ambiente (USEPA) impone los límites de las cantidades de ciertos contaminantes en el agua potable. En California, el Ministerio de Asuntos Exteriores de la Salud Pública (CDPH) regula la calidad de agua del grifo haciendo cumplir límites que son al menos tan rigurosos como el USEPA'S. Historicamente, los estándares de California han sido más estrictos que los federales.

Hay dos tipos de límites conocidos como estándares. Los estándares primarios lo protegen de sustancias que potencialmente podrían afectar su salud. Las normas establecen los Niveles Contaminantes Máximos (MCL, en inglés) que se permite del contaminante primario o secundario en el agua de beber. Los abastecedores de agua deben asegurarse de que la calidad de esta cumpla con los Niveles Contaminantes Máximos (o MCLs, en inglés). No todas las sustancias tienen un Nivel Contaminante Máximo. El plomo y el cobre, por ejemplo, son regulados, por cierto nivel de acción. Si cualquier sustancia química sobrepasa el nivel de acción, se dará la necesidad de un proceso de tratamiento para rebajar los niveles en el agua de beber. Los abastecedores de agua deben cumplir con los Niveles Contaminantes Máximos para asegurar la calidad del agua.

Las Metas para la Salud Pública (MSP [o PHGs, en inglés]) son establecidas por la agencia estatal de California-EPA. Las PHGs proveen más información con respecto a la calidad del agua, y son similares a los reglamentos federales nombrados Metas para Los Niveles de Contaminante *Maximos* (MNCM [o MCLGs, en inglés]). Las PHGs y MCLGs son metas a nivel recomendable. Las PHG y MCLG son ambas definidas como los niveles de contaminantes en el agua potable por debajo de los niveles donde no se esperan riesgos a la salud y no enforzables. Ambos niveles PHG y MCLG son concentraciones de una sustancia en las que no hay riesgos a la salud aún conocidos.

¿Cómo Interpreto Mi Informe de Calidad del Agua?

Aunque analizamos más de 100 sustancias, las normas nos requirieron que reportemos solo aquellas que se encuentran en el agua. La primer columna en la tabla de la calidad de agua muestra la lista de las sustancias detectadas en el agua. La siguiente columna muestra la lista de la concentracion promedio y el rango de concentraciones que se hallan encontrado en el agua que usted toma. En seguida están las listas de el MCL, el PHG y el MCLG, si estos son apropiados. La última columna describe las probables fuentes u origen de las sustancias detectadas en el agua potable.

Para revisar la calidad de su agua de beber, compare los valores por encima del promedio, mínimos y máximos y el Nivel Contaminante Máximo. Revise todos los químicos que se encuentran por encima del Nivel Contaminante Máximo. Si los químicos sobrepasan el Nivel Contaminante Máximo no significa que sea detrimental a la salud de inmediato. Más bien, se requiere que se realicen análisis más frecuentemente en el abastecimiento del agua por un corto período. Si los resultados muestran sobrepasar el MCL, el agua debe ser tratada para remover esa sustancia, o el abastecimiento de esta debe decomisionarse.

¿Por Qué Hay Tanta Publicidad Sobre La Calidad Del Agua Potable?

Las fuentes del agua potable (de ambas agua de la llave y agua embotellada) incluye ríos, lagos, arroyos, lagunas, embalses, manantiales, y pozos. Al pasar el agua por la superficie de los suelos o por la tierra, se disuelven minerales que ocurren al natural, y en algunas ocasiones, material radioactivo, al igual que pueden levantar sustancias generadas por la presencia de animales o por actividades humanas.

Entre los contaminantes que pueden existir en las fuentes de agua se incluyen:

- Contaminantes microbiales como los virus y la bacteria, los que pueden venir de las plantas de tratamiento de aguas negras, de los sistemas sépticos, de las operaciones de ganadería, y de la vida salvaje;

- Contaminantes inorgánicos, como las sales y los metales, los cuales pueden ocurrir naturalmente o como resultado del desagüe pluvial, industrial, o de alcantarillado, producción de gas natural y petróleo, minas y agricultura.
- Pesticidas y herbicidas, los cuales pueden venir de varias fuentes tales como la agricultura, del desagüe pluvial, y de usos residenciales;
- Contaminantes de otras sustancias químicas orgánicas, incluyendo químicos orgánicos volátiles y sintéticos que son productos de procesos industriales y de la producción de petróleo, y que pueden provenir de las estaciones de gasolina, desagües pluviales urbanos, y agricultura aplicación y de sistemas sépticos;
- Contaminantes radioactivos, los cuales pueden ocurrir naturalmente o que pueden ser resultados de las actividades de la producción de gas natural y minería.

Para asegurarse que el agua potable sea saludable, la USEPA y el Departamento impone reglamentos que limitan las cantidades de ciertos contaminantes en el agua que los sistemas públicos de agua proveen. Los reglamentos de Departamento también establecen límites de contaminantes en el agua embotellada la cual debe proveer la misma protección a la salud pública.

Toda el agua potable, incluyendo el agua embotellada, puede contener cantidades pequeñas de ciertos contaminantes. La presencia de contaminantes no necesariamente indica que haya algún riesgo de salud. Para más información acerca de contaminantes y riesgos a la salud favor de llamar a la USEPA encargada de proteger el agua potable al teléfono (1-800-426-4791). Usted puede obtener más información sobre el agua potable al conectarse al Internet en los siguientes domicilios:

- www.epa.gov/OGWDW (el sitio Web del USEPA)
- www.cdph.ca.gov (sitio Web de CDPH)

Si presente, los niveles elevados del plomo pueden causar el problema de salud serio, sobre todo para mujeres embarazadas y chiquitos. El plomo en el agua potable es principalmente de materiales y componentes asociados con líneas de servicios y a casa fontanería. Maywood Compañía de Echar agua Mutua el No 3 es responsable de proporcionar el agua potable de alta calidad, pero no puede controlar la variedad de materiales usados en la fontanería de componentes. Cuando su echar agua ha estado sentándose durante varias horas, usted puede minimizar el potencial para la exposición de plomo limpiando con agua su grifo durante 30 segundos a 2 minutos antes de usar el echar agua para beber o cocinarse. Si usted está preocupado por el plomo en su echar agua, usted puede desear hacer probar su echar agua. La información en el plomo en el agua potable, probando métodos, y pasos que usted puede tomar para minimizar la exposición está disponible de la Línea directa de Agua Potable Segura o en <http://www.epa.gov/safewater/lead>.

¿Debería Tomar Otras Precauciones?

Algunas personas pueden ser más vulnerables a los contaminantes en el agua potable que el público en general. Las personas que tienen problemas inmunológicos, o sea esas personas que estén en tratamiento por medio de quimioterapia cancerosa; personas que tienen órganos transplantados, o personas con SIDA o desórdenes inmunológicos, personas de edad avanzada, y los bebés que son particularmente susceptibles a ciertas infecciones. Estas personas deben de consultar a sus proveedores de salud médica. Las guías de la USEPA/Centros de Control de Enfermedades aconsejan cómo disminuir los riesgos para prevenir la infección de Cryptosporidium y otros contaminantes microbiales están disponibles por teléfono de la USEPA encargada de proteger el agua potable al teléfono (1-800-426-4791).

Valoración de su Abastecimiento de Agua

La compañía de agua de Maywood Mutual Número 3 condujo una valoración de su abastecimiento de aguas subterráneas en el 2001. El abastecimiento de aguas subterráneas es considerado mas vulnerable a químicos, procesos petroleros, y almacenaje; a líneas de petróleo; al chapado, acabado, y fabricación de metal; a plásticos y procesos sintéticos; a parques; al plomo; al escape de tanques bajo tierra; a talleres de carrocería; a talleres automotrices; a la manufactura electrónica y eléctrica; a talleres de maquinas; al proceso e imprenta de fotografías; a la manufactura y reparación de muebles; a la manufactura de casas; a tiendas de ferretería, partes, y madera; estacionamientos y centros comerciales con mas de 50 espacios para estacionamiento; autopistas y carreteras del estado; a ferrocarriles; a carreteras y calles; pozos y hoyos de supervisión; estaciones gasolineras; a viviendas de alta densidad (>1casa/0.5acre); a oficinas y clínicas medicas y dentales; a apartamentos y condominios; preservación de madera y tratamiento, y madera/pulpa/y procesamiento de papel y molinos. Una copia de la valoración aprobada puede ser obtenida llamando a Robert Rohlf al (323) 560-3657.

¿Cómo Puedo Participar en las Decisiones Sobre Asuntos Acerca del Agua Que Me Puedan Afectar ?

Los accionistas son bienvenidos asisten a las Reuniones de la junta directiva sostenidas el martes pasado de cada mes a las 16h30 en 6151 Avenida de Heliotropo Maywood, CA 90270.

¿Cómo Me Pongo En Contacto Con Mi Agencia del Agua Si Tengo Preguntas Sobre La Calidad Del Agua?

Si usted tiene preguntas específicas sobre la calidad del agua potable, por favor llame a Robert Rohlf (323) 560-3657.

¿Cómo Puedo Conservar Agua en Casa?

- Los · Fijan grifos agujereados en su casa – salvan hasta 20 galones cada día de cada agujero parado
- Los · Ahorran entre 15 y 50 galones cada vez por sólo lavando cargas máximas del lavado de ropa
- Los · Ajustan sus aspersores de modo que tierras de echar agua en su césped/jardín, no la acera/calzada – salven 500 galones por mes
- Los · Usan el pajote orgánico alrededor de plantas para reducir la evaporación – salvan cientos de galones un año
- Los · Usan showerhead eficiente de agua. Ellos son baratos, fáciles para instalar, y pueden salvarle hasta 750 galones por mes.

LA COMPANIA DE AGUA DE MAYWOOD MUTUAL NUMERO 3 INFORME DE CONFIANZA DE CONSUMIDOR de 2009

Resultados de muestreo de mas reciente pruebas en conformidad con los requerimientos para el agua potable señalado por el Estado y la Federación.

NORMAS PRIMARIAS PARA EL AGUA POTABLE - MONITOREO EN EL FUENTE - REQUIERE PARA PUBLICA SALUD

CONTAMINANTES ORGANICAS (g/l)	AGUAS SUBTERRANEA		PRIMARIAS MCL	MCLG or PHG	FUENTE TÍPICA
	PROMEDIO	RANGO			
Tetrachloroethylene (PCE)	ND	ND	5	0.06 (a)	Descarga de fábricas, de tintorerías, y de tiendas del automóvil (desengrasador del metal)
Tricloroetileno (TCE)	2.4	ND-4.2	5	0.8 (a)	Descarga de sitios que desengrasan del metal y de otras fábricas

INORGANICOS Muestra en 2007 - 2009 (b)					
Aluminio (mg/l)	ND	ND	1	0.6 (a)	Erosión de depósitos naturales; residuos de procesos de tratamiento del agua de superficie
Arsénico (g/l)	ND	ND	10	0.004	Erosión de depósitos naturales; basura de producción de cristal/electrónica; partido de desempate
Bario (mg/l)	ND	ND	1	2 (a)	Basura de la perforación petrolífera y descarga de la refinería del metal; erosión de depósitos naturales
Fluoruro (mg/l)	0.33	0.26-0.39	2.0	1 (a)	Erosión de depósitos naturales, aditivos al agua para reforzar los dientes
Nitrato (mg/l) as NO3	8.7	ND-14	45	45 (a)	Residuos de abono; lixiviación de fosas sépticas, aguas residuales; erosión de depósitos naturales

NORMAS PRIMARIAS PARA EL AGUA POTABLE - MONITOREO EN EL SISTEMA DE DISTRIBUCION - REQUIERE PARA PUBLICA SALUD

MICROBIALS	SISTEMA DE DISTRIBUCION		PRIMARIAS MCL	MCLG or PHG	
	PROMEDIO # POSITIVO	RANGO DE # POSITIVO			
Bacterias Totales del Coliform	0	0	< 1 positivo	0	Natural presente en ambiente
Coliform Fecal y Bacterias de E.Coli	0	0	0	0	Basura fecal humana y animal
Número de Violaciones Agudas	0	0	-	-	

	SISTEMA DE DISTRIBUCION		PRIMARIAS	MCLG	
	PROMEDIO	RANGO			
Turbiedad (NTU)	0.2	<1 - 0.7	TT	-	Salida del suelo

SUBPRODUCTOS DE DESINFECCION Y RESIDUALS (f)	SISTEMA DE DISTRIBUCION		PRIMARIAS MCL	MCLG or PHG	
	PROMEDIO	RANGO			
Trihalometanos-TTHMs (g/l)	25.2	ND-69.2	80	-	Subproducto de la desinfección con cloro del agua potable
Acido de Haloacetic - HAAs (g/l)	4.6	ND-16.2	60	-	Subproducto de la desinfección con cloro del agua potable
Residual Total De la Clorina (mg/l)	0.9	0.5-1.2	4.0 (g)	4.0 (h)	El desinfectante del agua potable agregó para el tratamiento

EN EL GOLPECITO COMPONENTES FISICOS 20 sitios muestreados en 2007	SISTEMA DE DISTRIBUCION		PRIMARIAS MCL	MCLG or PHG	
	90.0 porcentaje	# DE SITIOS SOBRE EL AL			
Cobre (mg/l)	ND (i)	0	1.3 AL	0.17 (a)	Corrosión interna de la plomería de la casa, erosión de depósitos naturales
Plomo (g/l)	ND (i)	0	15 AL	2 (a)	Corrosión interna de la plomería de la casa, descargas industriales del fabricante

ESTÁNDARES SECUNDARIOS SUPERVISADOS EN LOS PROPÓSITOS ESTETICOS DE SOURCE

Probado en 2007-2009 (b)

	AGUAS SUBTERRANEA		SECUNDARIOS MCL	MCLG or PHG	
	PROMEDIO	RANGO			
Índice de la agresividad (corrosividad)	13	13	No corrosivo	-	Balace de Natural/industrially-influenced de hydrogen/carbon/oxygen en agua
Aluminio (g/l) (i)	ND	ND	200	600 (a)	Erosión de depósitos naturales, residuo superficial del proceso del tratamiento de aguas
Cloruro (mg/l)	56	52-61	500	-	Runoff/leaching de depósitos naturales, influencia del agua de mar
Color (unidades del color)	5	ND-15	15	-	Materiales orgánicos naturales
Conductividad (uS/cm)	696.7	580-780	1,600	-	Sustancias que forman los iones cuando en el agua, influencia del agua de mar
Hierro (ug/l)	ND	ND	300	-	Leaching natural depositar
Manganeso (g/l)	8.7	ND-26	50	-	Leaching natural depositar
Olor (número del olor del umbral)	ND	ND	3	-	Materiales orgánicos naturales
Sulfato (mg/l)	102.7	48-140	500	-	Runoff/leaching de los depósitos naturales, basuras industriales
Disueltos Totales (mg/l)	450	370-500	1,000	-	Runoff/leaching de los depósitos naturales
Turbiedad (NTU)	0.19	ND-0.52	5	-	Salida del suelo

ESTANDARES SECUNDARIOS SUPERVISADOS EN LOS PROPOSITOS ESTETICOS DE LA DISTRIBUCION SYSTEM

GENERAL COMPONENTES FISICOS	SISTEMA DE DISTRIBUCION		SECUNDARIOS MCL	MCLG or PHG	
	PROMEDIO	RANGO			
Color (unidades del color)	<3	<3	15	-	Materiales orgánicos naturales
Olor (número del olor del umbral)	1	1.0-2.0	3	-	Materiales orgánicos naturales

PRODUCTOS QUIMICOS ADICIONALES DEL INTERES

Probado en 2007-2009 (b)

	AGUAS SUBTERRANEA	
	PROMEDIO	RANGO
Alcalinidad (mg/l)	180	170-200
Boro (g/l)	NA	NA
Bromato (g/l)	NA	NA
Calcio (mg/l)	66	46-76
Magnesio (mg/l)	17	12-20
N-Nitrosodimethylamine (ng/l)	NA	NA
Perchlorato (g/l)	0.43	ND-5.7
pH (unidad estándar)	8.2	8.1-8.3
Potasio (mg/l)	3.2	3.1-3.2
Sodio (mg/l)	59	48-70
Dureza Total (mg/l)	233	160-270
Carbón orgánico total (mg/l)	NA	NA
Vanadio (g/l)	NA	NA

NOTAS AL PIE DE LA PAGINA

- (a) Meta De la Salud Pública De California (PHG): Otros niveles consultivos enumeraron en esta columna son metas máximas federales del nivel del contaminante (MCLGs).
- (b) Indica las fechas muestreadas para las fuentes de la agua subterránea solamente.
- (c) El estándar grueso de la alfa también incluye el estándar Radium-226.
- (d) Conformidad de MCL basada en 4 cuartos consecutivos del muestreo.
- (e) El Radio Combinado 226 Radio 228 tiene un Nivel de Contaminante Máximo (MCL) de 5 pCi/L.
- (f) El promedio anual corriente calculaba promedio, la gama, y la conformidad de MCL.
- (g) Nivel Desinfectante Residual Máximo (MRDL)
- (h) Meta Liána Desinfectante Residual Máxima (MRDLG)
- (i) 90.0 el porcentaje del muestreo más reciente en el cliente seleccionado golpea ligeramente.
- (j) El aluminio tiene estándares primarios y secundarios.

ABREVIATURAS

- < = menos que
- mg/l = miligramos por litro o partes por millón (equivalente a 1 gota en 42 galones)
- NA = componente no analizado
- ND = componente no detectado en el límite de divulgación
- ng/l = nanogramos por litro o partes por trillón (equivalente a 1 gota en 42,000,000 galones)
- g/l = microgramos por litro o partes por mil millones (equivalente a 1 gota en 42,000 galones)

NTU = unidades nephelometric de la turbiedad
SI = índice de la saturación

pCi/l = picocuries por litro
uS/cm = microSiemens por centímetro

DEFINICIONES

- Nivel Máximo Del Contaminante (MCL):** El nivel más alto de un contaminante que se permite en agua potable. MCLs primarios se fijan como cerca del PHGs (o de MCLGs) como están económicamente y tecnológicamente factible.
- MCLs secundarios se fijan para proteger el olor, el gusto, y el aspecto del agua potable.
- Meta Máxima Del Nivel Del Contaminante (MCLG):** El nivel de un contaminante en el agua potable debajo de la cual no hay riesgo sabido o previsto a la salud. MCLGs son fijados por la agencia de protección del medio ambiente de ESTADOS UNIDOS.
- Nivel Desinfectante Residual Máximo (MRDL):** El nivel de un desinfectante agregó para el tratamiento de aguas que no se puede exceder en el golpecito del consumidor.
- Meta Liána Desinfectante Residual Máxima (MRDLG):** El nivel de un desinfectante agregó para el tratamiento de aguas debajo de el cual no hay riesgo sabido o previsto a la salud. MRDLGs es fijado por la agencia de protección del medio ambiente de ESTADOS UNIDOS.
- Meta De la Salud Pública (PHG):** El nivel de un contaminante en el agua potable debajo de la cual no hay riesgo sabido o previsto a la salud. PHGs es fijado por la agencia de protección del medio ambiente de California.
- Técnica Del Tratamiento (TT):** Un proceso requerido se presupone reducir el nivel de un contaminante en agua potable.
- Nivel Regulador De la Acción (AL):** La concentración de un contaminante que, si está excedido, acciona el tratamiento u otros requisitos que un sistema del agua debe seguir.
- Estándar Primario Del Agua Potable (PDWS):** MCLs y MRDLs para los contaminantes que afectan salud junto con sus requisitos de la supervisión y de divulgación, y requisitos del tratamiento de aguas.
- Estándar de Agua Secundario (SDWS):** El MCLs y MRDLs para contaminantes que afectan las calidades estéticas del agua.

APPENDIX B
MANGANESE, TCE, AND PERCHLORATE CONCENTRATIONS

APPENDIX B
Manganese Concentrations
Maywood Mutual Water Co. #1

SOURCE_NAM	SAMPLE_D	MANGANESE	LAB_NAME
WELL 03	1/5/2009	ND(20)	CLINICAL LABORATORIES OF SAN BERNARDINO
WELL 03	1/20/2009	ND(20)	CLINICAL LABORATORIES OF SAN BERNARDINO
WELL 03	2/2/2009	ND(20)	CLINICAL LABORATORIES OF SAN BERNARDINO
WELL 03	2/17/2009	ND(20)	CLINICAL LABORATORIES OF SAN BERNARDINO
WELL 03	2/20/2009	ND(20)	TESTAMERICA - ONTARIO (FORMERLY DEL MAR)
WELL 03	3/2/2009	ND(20)	CLINICAL LABORATORIES OF SAN BERNARDINO
WELL 03	4/6/2009	ND(20)	CLINICAL LABORATORIES OF SAN BERNARDINO
WELL 03	5/7/2009	ND(20)	TESTAMERICA - IRVINE (FORMERLY DEL MAR)
WELL 03	6/1/2009	ND(20)	CLINICAL LABORATORIES OF SAN BERNARDINO
WELL 03	7/6/2009	ND(20)	CLINICAL LABORATORIES OF SAN BERNARDINO
WELL 03	8/3/2009	ND(20)	CLINICAL LABORATORIES OF SAN BERNARDINO
WELL 03	8/20/2009	ND(20)	CLINICAL LABORATORIES OF SAN BERNARDINO
WELL 03	8/21/2009	ND(20)	TESTAMERICA - IRVINE (FORMERLY DEL MAR)
WELL 03	8/27/2009	ND(20)	CLINICAL LABORATORIES OF SAN BERNARDINO
WELL 03	8/31/2009	ND(20)	CLINICAL LABORATORIES OF SAN BERNARDINO
WELL 03	9/3/2009	ND(20)	CLINICAL LABORATORIES OF SAN BERNARDINO
WELL 03	9/8/2009	ND(20)	CLINICAL LABORATORIES OF SAN BERNARDINO
WELL 03	10/5/2009	ND(20)	CLINICAL LABORATORIES OF SAN BERNARDINO
WELL 03	11/2/2009	ND(20)	CLINICAL LABORATORIES OF SAN BERNARDINO
WELL 03	11/19/2009	31	TESTAMERICA - IRVINE (FORMERLY DEL MAR)
WELL 03	12/7/2009	70	CLINICAL LABORATORIES OF SAN BERNARDINO
2009 AVERAGE		13.9	
WELL 04	1/5/2009	69	CLINICAL LABORATORIES OF SAN BERNARDINO
WELL 04	1/20/2009	91	CLINICAL LABORATORIES OF SAN BERNARDINO
WELL 04	2/2/2009	80	CLINICAL LABORATORIES OF SAN BERNARDINO
WELL 04	2/17/2009	82	CLINICAL LABORATORIES OF SAN BERNARDINO
WELL 04	2/20/2009	85	TESTAMERICA - ONTARIO (FORMERLY DEL MAR)
WELL 04	3/2/2009	78	CLINICAL LABORATORIES OF SAN BERNARDINO
WELL 04	4/6/2009	77	CLINICAL LABORATORIES OF SAN BERNARDINO
WELL 04	5/7/2009	78	TESTAMERICA - IRVINE (FORMERLY DEL MAR)
WELL 04	6/1/2009	79	CLINICAL LABORATORIES OF SAN BERNARDINO
WELL 04	7/6/2009	74	CLINICAL LABORATORIES OF SAN BERNARDINO
WELL 04	8/3/2009	77	CLINICAL LABORATORIES OF SAN BERNARDINO
WELL 04	8/21/2009	92	TESTAMERICA - IRVINE (FORMERLY DEL MAR)
WELL 04	9/8/2009	81	CLINICAL LABORATORIES OF SAN BERNARDINO
WELL 04	10/5/2009	76	CLINICAL LABORATORIES OF SAN BERNARDINO
WELL 04	11/2/2009	84	CLINICAL LABORATORIES OF SAN BERNARDINO
WELL 04	11/19/2009	85	TESTAMERICA - IRVINE (FORMERLY DEL MAR)
WELL 04	12/7/2009	110	CLINICAL LABORATORIES OF SAN BERNARDINO
2009 AVERAGE		82.2	

Data Source: California Department of Public Health, November 2010

Concentrations are in micrograms per liter (ug/L)

ND(20) - Not detected above the reporting limit, if provided

For calculation purposes, results reported as ND are assumed to have a half of the laboratory reporting limit, e.g., a value of 10 µg/L is used for ND(20).

APPENDIX B
Manganese Concentrations
Maywood Mutual Water Co. #2

SOURCE NAME	SAMPLE DAT	MANGANESE	LAB NAME
52ND STREET WELL	1/5/2009	58	CLINICAL LABORATORIES OF SAN BERNARDINO
52ND STREET WELL	1/12/2009	71	CLINICAL LABORATORIES OF SAN BERNARDINO
52ND STREET WELL	1/16/2009	58	TESTAMERICA - IRVINE (FORMERLY DEL MAR)
52ND STREET WELL	1/19/2009	45	CLINICAL LABORATORIES OF SAN BERNARDINO
52ND STREET WELL	1/26/2009	55	CLINICAL LABORATORIES OF SAN BERNARDINO
52ND STREET WELL	2/2/2009	150	CLINICAL LABORATORIES OF SAN BERNARDINO
52ND STREET WELL	2/9/2009	96	CLINICAL LABORATORIES OF SAN BERNARDINO
52ND STREET WELL	2/16/2009	55	CLINICAL LABORATORIES OF SAN BERNARDINO
52ND STREET WELL	2/20/2009	61	TESTAMERICA - IRVINE (FORMERLY DEL MAR)
52ND STREET WELL	2/23/2009	36	CLINICAL LABORATORIES OF SAN BERNARDINO
52ND STREET WELL	3/2/2009	83	CLINICAL LABORATORIES OF SAN BERNARDINO
52ND STREET WELL	3/9/2009	84	CLINICAL LABORATORIES OF SAN BERNARDINO
52ND STREET WELL	3/12/2009	94	TESTAMERICA - IRVINE (FORMERLY DEL MAR)
52ND STREET WELL	3/16/2009	86	CLINICAL LABORATORIES OF SAN BERNARDINO
52ND STREET WELL	3/23/2009	90	CLINICAL LABORATORIES OF SAN BERNARDINO
52ND STREET WELL	3/30/2009	86	CLINICAL LABORATORIES OF SAN BERNARDINO
52ND STREET WELL	4/6/2009	80	CLINICAL LABORATORIES OF SAN BERNARDINO
52ND STREET WELL	4/13/2009	77	CLINICAL LABORATORIES OF SAN BERNARDINO
52ND STREET WELL	4/20/2009	110	CLINICAL LABORATORIES OF SAN BERNARDINO
52ND STREET WELL	4/21/2009	81	CLINICAL LABORATORIES OF SAN BERNARDINO
52ND STREET WELL	4/27/2009	82	CLINICAL LABORATORIES OF SAN BERNARDINO
52ND STREET WELL	5/4/2009	72	CLINICAL LABORATORIES OF SAN BERNARDINO
52ND STREET WELL	5/7/2009	77	TESTAMERICA - ONTARIO (FORMERLY DEL MAR)
52ND STREET WELL	5/11/2009	74	CLINICAL LABORATORIES OF SAN BERNARDINO
52ND STREET WELL	5/18/2009	76	CLINICAL LABORATORIES OF SAN BERNARDINO
52ND STREET WELL	5/26/2009	69	CLINICAL LABORATORIES OF SAN BERNARDINO
52ND STREET WELL	6/1/2009	75	CLINICAL LABORATORIES OF SAN BERNARDINO
52ND STREET WELL	6/8/2009	72	CLINICAL LABORATORIES OF SAN BERNARDINO
52ND STREET WELL	6/12/2009	86	TESTAMERICA - IRVINE (FORMERLY DEL MAR)
52ND STREET WELL	6/15/2009	68	CLINICAL LABORATORIES OF SAN BERNARDINO
52ND STREET WELL	6/22/2009	77	CLINICAL LABORATORIES OF SAN BERNARDINO
52ND STREET WELL	6/29/2009	71	CLINICAL LABORATORIES OF SAN BERNARDINO
52ND STREET WELL	7/6/2009	65	CLINICAL LABORATORIES OF SAN BERNARDINO
52ND STREET WELL	7/13/2009	62	CLINICAL LABORATORIES OF SAN BERNARDINO
52ND STREET WELL	7/17/2009	70	TESTAMERICA - IRVINE (FORMERLY DEL MAR)
52ND STREET WELL	7/20/2009	66	CLINICAL LABORATORIES OF SAN BERNARDINO
52ND STREET WELL	7/27/2009	66	CLINICAL LABORATORIES OF SAN BERNARDINO
52ND STREET WELL	8/3/2009	59	CLINICAL LABORATORIES OF SAN BERNARDINO
52ND STREET WELL	8/10/2009	75	CLINICAL LABORATORIES OF SAN BERNARDINO
52ND STREET WELL	8/14/2009	71	TESTAMERICA - IRVINE (FORMERLY DEL MAR)
52ND STREET WELL	8/17/2009	72	CLINICAL LABORATORIES OF SAN BERNARDINO
52ND STREET WELL	8/24/2009	72	CLINICAL LABORATORIES OF SAN BERNARDINO
52ND STREET WELL	8/31/2009	72	CLINICAL LABORATORIES OF SAN BERNARDINO
52ND STREET WELL	9/8/2009	72	CLINICAL LABORATORIES OF SAN BERNARDINO
52ND STREET WELL	9/14/2009	60	CLINICAL LABORATORIES OF SAN BERNARDINO
52ND STREET WELL	9/21/2009	68	CLINICAL LABORATORIES OF SAN BERNARDINO
52ND STREET WELL	9/24/2009	69	TESTAMERICA - IRVINE (FORMERLY DEL MAR)
52ND STREET WELL	9/28/2009	66	CLINICAL LABORATORIES OF SAN BERNARDINO
52ND STREET WELL	10/5/2009	88	CLINICAL LABORATORIES OF SAN BERNARDINO
52ND STREET WELL	10/12/2009	67	CLINICAL LABORATORIES OF SAN BERNARDINO
52ND STREET WELL	10/19/2009	71	CLINICAL LABORATORIES OF SAN BERNARDINO
52ND STREET WELL	10/26/2009	67	CLINICAL LABORATORIES OF SAN BERNARDINO
52ND STREET WELL	10/27/2009	62	TESTAMERICA - IRVINE (FORMERLY DEL MAR)
52ND STREET WELL	11/2/2009	60	CLINICAL LABORATORIES OF SAN BERNARDINO

APPENDIX B
Manganese Concentrations
Maywood Mutual Water Co. #2

SOURCE NAME	SAMPLE DAT	MANGANESE	LAB NAME
52ND STREET WELL	11/9/2009	68	CLINICAL LABORATORIES OF SAN BERNARDINO
52ND STREET WELL	11/16/2009	69	CLINICAL LABORATORIES OF SAN BERNARDINO
52ND STREET WELL	11/19/2009	70	TESTAMERICA - IRVINE (FORMERLY DEL MAR)
52ND STREET WELL	11/23/2009	63	CLINICAL LABORATORIES OF SAN BERNARDINO
52ND STREET WELL	11/30/2009	71	CLINICAL LABORATORIES OF SAN BERNARDINO
52ND STREET WELL	12/7/2009	74	CLINICAL LABORATORIES OF SAN BERNARDINO
52ND STREET WELL	12/14/2009	78	CLINICAL LABORATORIES OF SAN BERNARDINO
52ND STREET WELL	12/14/2009	72	TESTAMERICA - IRVINE (FORMERLY DEL MAR)
52ND STREET WELL	12/21/2009	70	CLINICAL LABORATORIES OF SAN BERNARDINO
52ND STREET WELL	12/28/2009	100	CLINICAL LABORATORIES OF SAN BERNARDINO
2009 AVERAGE		73.3	
MAY AVENUE WELL	1/5/2009	62	CLINICAL LABORATORIES OF SAN BERNARDINO
MAY AVENUE WELL	1/12/2009	64	CLINICAL LABORATORIES OF SAN BERNARDINO
MAY AVENUE WELL	1/16/2009	61	TESTAMERICA - IRVINE (FORMERLY DEL MAR)
MAY AVENUE WELL	1/19/2009	65	CLINICAL LABORATORIES OF SAN BERNARDINO
MAY AVENUE WELL	1/26/2009	70	CLINICAL LABORATORIES OF SAN BERNARDINO
MAY AVENUE WELL	2/2/2009	58	CLINICAL LABORATORIES OF SAN BERNARDINO
MAY AVENUE WELL	2/9/2009	51	CLINICAL LABORATORIES OF SAN BERNARDINO
MAY AVENUE WELL	2/16/2009	57	CLINICAL LABORATORIES OF SAN BERNARDINO
MAY AVENUE WELL	2/20/2009	68	TESTAMERICA - ONTARIO (FORMERLY DEL MAR)
MAY AVENUE WELL	2/23/2009	63	CLINICAL LABORATORIES OF SAN BERNARDINO
MAY AVENUE WELL	3/2/2009	59	CLINICAL LABORATORIES OF SAN BERNARDINO
MAY AVENUE WELL	3/9/2009	62	CLINICAL LABORATORIES OF SAN BERNARDINO
MAY AVENUE WELL	3/12/2009	64	TESTAMERICA - IRVINE (FORMERLY DEL MAR)
MAY AVENUE WELL	3/16/2009	65	CLINICAL LABORATORIES OF SAN BERNARDINO
MAY AVENUE WELL	3/23/2009	64	CLINICAL LABORATORIES OF SAN BERNARDINO
MAY AVENUE WELL	3/30/2009	63	CLINICAL LABORATORIES OF SAN BERNARDINO
MAY AVENUE WELL	4/6/2009	62	CLINICAL LABORATORIES OF SAN BERNARDINO
MAY AVENUE WELL	4/13/2009	60	CLINICAL LABORATORIES OF SAN BERNARDINO
MAY AVENUE WELL	4/20/2009	63	CLINICAL LABORATORIES OF SAN BERNARDINO
MAY AVENUE WELL	4/20/2009	65	TESTAMERICA - IRVINE (FORMERLY DEL MAR)
MAY AVENUE WELL	4/27/2009	62	CLINICAL LABORATORIES OF SAN BERNARDINO
MAY AVENUE WELL	5/4/2009	58	CLINICAL LABORATORIES OF SAN BERNARDINO
MAY AVENUE WELL	5/7/2009	60	TESTAMERICA - ONTARIO (FORMERLY DEL MAR)
MAY AVENUE WELL	5/11/2009	60	CLINICAL LABORATORIES OF SAN BERNARDINO
MAY AVENUE WELL	5/18/2009	61	CLINICAL LABORATORIES OF SAN BERNARDINO
MAY AVENUE WELL	5/26/2009	58	CLINICAL LABORATORIES OF SAN BERNARDINO
MAY AVENUE WELL	6/1/2009	62	CLINICAL LABORATORIES OF SAN BERNARDINO
MAY AVENUE WELL	6/8/2009	62	CLINICAL LABORATORIES OF SAN BERNARDINO
MAY AVENUE WELL	6/12/2009	60	TESTAMERICA - IRVINE (FORMERLY DEL MAR)
MAY AVENUE WELL	6/15/2009	93	CLINICAL LABORATORIES OF SAN BERNARDINO
MAY AVENUE WELL	6/22/2009	62	CLINICAL LABORATORIES OF SAN BERNARDINO
MAY AVENUE WELL	6/29/2009	58	CLINICAL LABORATORIES OF SAN BERNARDINO
MAY AVENUE WELL	7/6/2009	54	CLINICAL LABORATORIES OF SAN BERNARDINO
MAY AVENUE WELL	7/13/2009	52	CLINICAL LABORATORIES OF SAN BERNARDINO
MAY AVENUE WELL	7/17/2009	59	TESTAMERICA - IRVINE (FORMERLY DEL MAR)
MAY AVENUE WELL	7/20/2009	58	CLINICAL LABORATORIES OF SAN BERNARDINO
MAY AVENUE WELL	7/27/2009	58	CLINICAL LABORATORIES OF SAN BERNARDINO
MAY AVENUE WELL	8/3/2009	51	CLINICAL LABORATORIES OF SAN BERNARDINO
MAY AVENUE WELL	8/10/2009	65	CLINICAL LABORATORIES OF SAN BERNARDINO
MAY AVENUE WELL	8/14/2009	64	TESTAMERICA - ONTARIO (FORMERLY DEL MAR)
MAY AVENUE WELL	8/17/2009	63	CLINICAL LABORATORIES OF SAN BERNARDINO
MAY AVENUE WELL	8/24/2009	63	CLINICAL LABORATORIES OF SAN BERNARDINO

APPENDIX B
Manganese Concentrations
Maywood Mutual Water Co. #2

SOURCE NAME	SAMPLE DAT	MANGANESE	LAB NAME
MAY AVENUE WELL	8/31/2009	63	CLINICAL LABORATORIES OF SAN BERNARDINO
MAY AVENUE WELL	9/8/2009	64	CLINICAL LABORATORIES OF SAN BERNARDINO
MAY AVENUE WELL	9/14/2009	53	CLINICAL LABORATORIES OF SAN BERNARDINO
MAY AVENUE WELL	9/21/2009	63	CLINICAL LABORATORIES OF SAN BERNARDINO
MAY AVENUE WELL	9/28/2009	59	CLINICAL LABORATORIES OF SAN BERNARDINO
MAY AVENUE WELL	10/5/2009	64	CLINICAL LABORATORIES OF SAN BERNARDINO
MAY AVENUE WELL	10/12/2009	60	CLINICAL LABORATORIES OF SAN BERNARDINO
MAY AVENUE WELL	10/19/2009	64	CLINICAL LABORATORIES OF SAN BERNARDINO
MAY AVENUE WELL	10/26/2009	61	CLINICAL LABORATORIES OF SAN BERNARDINO
MAY AVENUE WELL	10/27/2009	54	TESTAMERICA - IRVINE (FORMERLY DEL MAR)
MAY AVENUE WELL	11/2/2009	73	CLINICAL LABORATORIES OF SAN BERNARDINO
MAY AVENUE WELL	11/9/2009	62	CLINICAL LABORATORIES OF SAN BERNARDINO
MAY AVENUE WELL	11/16/2009	61	CLINICAL LABORATORIES OF SAN BERNARDINO
MAY AVENUE WELL	11/19/2009	63	TESTAMERICA - IRVINE (FORMERLY DEL MAR)
MAY AVENUE WELL	11/23/2009	58	CLINICAL LABORATORIES OF SAN BERNARDINO
MAY AVENUE WELL	11/30/2009	62	CLINICAL LABORATORIES OF SAN BERNARDINO
MAY AVENUE WELL	12/7/2009	62	CLINICAL LABORATORIES OF SAN BERNARDINO
MAY AVENUE WELL	12/14/2009	62	CLINICAL LABORATORIES OF SAN BERNARDINO
MAY AVENUE WELL	12/14/2009	62	TESTAMERICA - IRVINE (FORMERLY DEL MAR)
MAY AVENUE WELL	12/21/2009	60	CLINICAL LABORATORIES OF SAN BERNARDINO
MAY AVENUE WELL	12/28/2009	65	CLINICAL LABORATORIES OF SAN BERNARDINO
2009 AVERAGE		61.7	

Data Source: California Department of Public Health, November 2010
Concentrations are in micrograms per liter (ug/L)

APPENDIX B
Manganese, TCE, and Perchlorate Concentrations
Maywood Mutual Water Co. #3

SOURCE	SAMPLE DATE	MANGANESE	PERCHLORATE	TCE	LAB NAME
PROSPECT WELL 01	2/22/2008	NA	ND(4)	NA	TESTAMERICA - ONTARIO (FORMERLY DEL MAR)
PROSPECT WELL 01	4/24/2008	ND(20)	NA	NA	TESTAMERICA - IRVINE (FORMERLY DEL MAR)
PROSPECT WELL 01	5/23/2008	NA	NA	2	TESTAMERICA - IRVINE (FORMERLY DEL MAR)
PROSPECT WELL 01	5/23/2008	NA	ND(4)	NA	TESTAMERICA - ONTARIO (FORMERLY DEL MAR)
PROSPECT WELL 01	9/29/2008	NA	NA	1.9	TESTAMERICA - IRVINE (FORMERLY DEL MAR)
PROSPECT WELL 01	9/29/2008	NA	NA	2.3	TESTAMERICA - ONTARIO (FORMERLY DEL MAR)
PROSPECT WELL 01	11/18/2008	NA	NA	2.3	TESTAMERICA - ONTARIO (FORMERLY DEL MAR)
PROSPECT WELL 01	2/20/2009	NA	NA	2	TESTAMERICA - ONTARIO (FORMERLY DEL MAR)
PROSPECT WELL 01	5/11/2009	NA	ND(4)	NA	TESTAMERICA - ONTARIO (FORMERLY DEL MAR)
PROSPECT WELL 01	8/14/2009	NA	NA	1.8	TESTAMERICA - IRVINE (FORMERLY DEL MAR)
PROSPECT WELL 01	8/14/2009	NA	NA	2.4	TESTAMERICA - ONTARIO (FORMERLY DEL MAR)
PROSPECT WELL 01	11/20/2009	NA	NA	4.5	TESTAMERICA - IRVINE (FORMERLY DEL MAR)
2009 AVERAGE			ND(4)	2.7	
WELL 04 (District)	4/24/2008	26	NA	NA	TESTAMERICA - IRVINE (FORMERLY DEL MAR)
WELL 04 (District)	5/23/2008	NA	NA	ND(0.5)	TESTAMERICA - IRVINE (FORMERLY DEL MAR)
WELL 04 (District)	5/23/2008	NA	ND(4)	NA	TESTAMERICA - ONTARIO (FORMERLY DEL MAR)
WELL 04 (District)	9/29/2008	NA	NA	ND(0.5)	TESTAMERICA - IRVINE (FORMERLY DEL MAR)
WELL 04 (District)	5/11/2009	NA	ND(4)	NA	TESTAMERICA - ONTARIO (FORMERLY DEL MAR)
WELL 04 (District)	9/22/2009	NA	NA	ND(0.5)	TESTAMERICA - IRVINE (FORMERLY DEL MAR)
2009 AVERAGE			ND(4)	ND(0.5)	
WELL 07 (Warehouse)	4/24/2008	NA	NA	2.8	TESTAMERICA - IRVINE (FORMERLY DEL MAR)
WELL 07 (Warehouse)	4/24/2008	ND(20)	NA	NA	TESTAMERICA - ONTARIO (FORMERLY DEL MAR)
WELL 07 (Warehouse)	5/23/2008	NA	5.7	NA	TESTAMERICA - IRVINE (FORMERLY DEL MAR)
WELL 07 (Warehouse)	9/29/2008	NA	ND	NA	TESTAMERICA - IRVINE (FORMERLY DEL MAR)
WELL 07 (Warehouse)	12/1/2008	NA	ND	NA	CLINICAL LABORATORIES OF SAN BERNARDINO
WELL 07 (Warehouse)	1/5/2009	NA	ND	NA	CLINICAL LABORATORIES OF SAN BERNARDINO
WELL 07 (Warehouse)	2/11/2009	NA	4.1	NA	CLINICAL LABORATORIES OF SAN BERNARDINO
WELL 07 (Warehouse)	2/20/2009	NA	ND	NA	TESTAMERICA - IRVINE (FORMERLY DEL MAR)
WELL 07 (Warehouse)	4/6/2009	NA	ND	NA	CLINICAL LABORATORIES OF SAN BERNARDINO
WELL 07 (Warehouse)	4/9/2009	NA	ND(4)	NA	CLINICAL LABORATORIES OF SAN BERNARDINO
WELL 07 (Warehouse)	4/9/2009	NA	ND	NA	TESTAMERICA - IRVINE (FORMERLY DEL MAR)
WELL 07 (Warehouse)	5/11/2009	NA	ND(4)	NA	CLINICAL LABORATORIES OF SAN BERNARDINO
WELL 07 (Warehouse)	5/11/2009	NA	NA	4.2	TESTAMERICA - IRVINE (FORMERLY DEL MAR)
WELL 07 (Warehouse)	5/11/2009	NA	ND	NA	TESTAMERICA - ONTARIO (FORMERLY DEL MAR)
WELL 07 (Warehouse)	6/9/2009	NA	ND	NA	CLINICAL LABORATORIES OF SAN BERNARDINO
WELL 07 (Warehouse)	7/8/2009	NA	ND	NA	CLINICAL LABORATORIES OF SAN BERNARDINO
WELL 07 (Warehouse)	8/3/2009	NA	ND(4)	NA	CLINICAL LABORATORIES OF SAN BERNARDINO
WELL 07 (Warehouse)	8/14/2009	NA	NA	2.8	TESTAMERICA - IRVINE (FORMERLY DEL MAR)
WELL 07 (Warehouse)	8/14/2009	NA	ND	NA	TESTAMERICA - ONTARIO (FORMERLY DEL MAR)
WELL 07 (Warehouse)	9/8/2009	NA	ND(4)	3.8	CLINICAL LABORATORIES OF SAN BERNARDINO
WELL 07 (Warehouse)	11/20/2009	NA	ND(4)	3.3	TESTAMERICA - IRVINE (FORMERLY DEL MAR)
2009 AVERAGE			ND(4)	3.5	

Data Source: California Department of Public Health, November 2010

NA - Data not available

ND(20) - Not detected above the reporting limit, if provided

TCE - Trichloroethene

Concentrations are in micrograms per liter (ug/L)

For calculation purposes, results reported as ND are assumed to have a half of the laboratory reporting limit, e.g., a value of 10 ug/L is used for ND(20).

APPENDIX C

**MANGANESE AND TCE CONCENTRATIONS IN PUBLIC WATER SUPPLY IN
COMMUNITIES WITHIN A 20-MILE RADIUS OF CITY OF MAYWOOD**

APPENDIX C

Manganese and TCE Concentrations In Public Water Supply Within 20-Mile Radius of City of Maywood

City/Community	Purveyor	2009 CCR					Calculated Conc. Based On % of Source Used			
		Groundwater		MWD Water Used	MWD Water %	Ground-water %	Mn		TCE	
		Mn	TCE				Max	Min	Max	Min
		ug/L	ug/L	ug/L	ug/L	ug/L	ug/L	ug/L	ug/L	
Alhambra	City of Alhambra Utilities Department	NA	0.8	Yes	20	80	10.0	10.0	0.69	0.69
Altadena	Lincoln Avenue Water Company	NA	NA	Yes	38	62	10.0	10.0	0.25	0.25
Anaheim	Anaheim Public Utilities	NA	NA	Yes	NA	NA	10.0	10.0	0.25	0.25
Arcadia	City of Arcadia	NA	NA	Yes	NA	NA	10.0	10.0	0.25	0.25
Artesia	Golden State Water Company	NA	ND	Yes	NA	NA	10.0	10.0	0.25	0.25
Azusa	Azusa Light & Water	NA	NA	Yes	35	65	10.0	10.0	0.25	0.25
Baldwin Hills	California American Water	0.009	0.2	Yes	NA	NA	10.0	10.0	0.25	0.25
Baldwin Park	Valley County Water District	NA	0.6	Yes	NA	NA	10.0	10.0	0.25	0.60
Bell	Golden State Water Company	ND	ND	Yes	NA	NA	10.0	10.0	0.25	0.25
Bell Gardens	City of Bell Gardens	ND	NA	Yes	68.6	31.4	10.0	10.0	0.25	0.25
Bell Gardens	Golden State Water Company	ND	ND	Yes	NA	NA	10.0	10.0	0.25	0.25
Bellflower	Bellflower Home Gardern Water Company	11.6	NA	Yes	19	81	11.3	11.3	0.25	0.25
Bellflower	Bellflower Municipal Water System	250.7	NA	Yes	NA	NA	10.0	250.7	0.25	0.25
Bellflower Norwalk	Park Water Company	NA	NA	Yes	74	26	10.0	10.0	0.25	0.25
Beverly Hills	City of Beverly Hills Public Works and Transportation Department	NA	NA	Yes	90	10	10.0	10.0	0.25	0.25
Brea	City of Brea Water Division	NA	1.0	Yes	NA	NA	10.0	10.0	0.25	1.00
Buena Park	City of Buena Park Water Department	<20	NA	Yes	NA	NA	10.0	10.0	0.25	0.25
Burbank	Burbank Water an Power	NA	NA	Yes	57	43	10.0	10.0	0.25	0.25
Cerritos	City of Cerritos Department of Water and Power	44	<0.5	Yes	4.14	95.86	42.6	42.6	0.25	0.25
City of Industry	Industry Public Utilities	NA	NA	No	0	100	10.0	10.0	0.25	0.25
Commerce	California Water Service Company	NA	0.8	Yes	NA	NA	10.0	10.0	0.25	0.80
Compton	City of Compton	29.3	NA	Yes	21	79	25.2	25.2	0.25	0.25
Compton	Park Water Company	NA	NA	Yes	100	0	10.0	10.0	0.25	0.25
Compton	Sativa Los Angeles County Water District	ND	NA	No	0	100	10.0	10.0	0.25	0.25
Covina	City of Covina	NA	NA	Yes	NA	NA	10.0	10.0	0.25	0.25
Covina	Covina Irrigating company	ND	ND	Yes	NA	NA	10.0	10.0	0.25	0.25
Cudahy	Tract 180 Mutual Water Company	ND	2.28	No	0	100	10.0	10.0	2.28	2.28
Cudahy	Tract 349 Mutual Water Company	52	0.2	No	0	100	52.0	52.0	0.25	0.25
Cypress, Los Almitos, Stanton	Golden State Water Company	ND	NA	Yes	NA	NA	10.0	10.0	0.25	0.25
Dominguez	California Water Service Company	5.6	NA	Yes	NA	NA	10.0	10.0	0.25	0.25
Downey	City of Downey	NA	0.02	No	0	100	10.0	10.0	0.25	0.25
Duarte	California American Water	NA	NA	No	0	100	10.0	10.0	0.25	0.25

APPENDIX C

Manganese and TCE Concentrations In Public Water Supply Within 20-Mile Radius of City of Maywood

City/Community	Purveyor	2009 CCR					Calculated Conc. Based On % of Source Used			
		Groundwater		MWD Water Used	MWD Water %	Ground-water %	Mn		TCE	
		Mn	TCE				Max	Min	Max	Min
		ug/L	ug/L	ug/L	ug/L	ug/L	ug/L			
East Los Angeles	California Water Service Company	7.4	0.4	Yes	NA	NA	10.0	10.0	0.25	0.40
East Pasadena	East Pasadena Water Company	NA	0.45	No	0	100	10.0	10.0	0.45	0.45
El Monte	City of El Monte Water Department	NA	ND	No	0	100	10.0	10.0	0.25	0.25
El Monte	Rurban Homes Mutual Co.	ND	NA	No	0	100	10.0	10.0	0.25	0.25
El Monte, Montbello, Rosemead	San Gabriel Valley Water Company	1	ND	No	0	100	10.0	10.0	0.25	0.25
Florence	Golden State Water Company	NA	ND	Yes	NA	NA	10.0	10.0	0.25	0.25
Fountain Valley	City of Fountain Valley Water Department	NA	NA	Yes	NA	NA	10.0	10.0	0.25	0.25
Fullerton	California Water Utilities	NA	0.7	Yes	NA	NA	10.0	10.0	0.25	0.70
Garden Grove	Garden Grove Water Services Division	NA	NA	Yes	NA	NA	10.0	10.0	0.25	0.25
Glendale	City of Glendale Water & Power	ND	NA	Yes	74	26	10.0	10.0	0.25	0.25
Glendora	City of Glendora	NA	NA	Yes	NA	NA	10.0	10.0	0.25	0.25
Glendora, Covina, West Covina, La Puente, Industry, Hacienda Heights	Suburban Water Systems	NA	ND	Yes	NA	NA	10.0	10.0	0.25	0.25
Hawthorne	California Water Service Company	NA	NA	Yes	NA	NA	10.0	10.0	0.25	0.25
Hemlock	Hemlock Mutual Water Company	NA	NA	No	0	100	10.0	10.0	0.25	0.25
Hollydale	Golden State Water Company	NA	NA	No	0	100	10.0	10.0	0.25	0.25
Huntington Park	City of Huntington Park	20.6	0.37	Yes	20	80	18.5	18.5	0.35	0.35
Huntington Beach	City of Huntington Beach Utilities Division	NA	NA	Yes	33	67	10.0	10.0	0.25	0.25
Inglewood	California Water Utilities	NA	NA	Yes	NA	NA	10.0	10.0	0.25	0.25
La Canada Flintridge	La Canada Irrigation District	NA	0.9	Yes	90	10	10.0	10.0	0.32	0.32
La Canada Flintridge	Valley Water Company	NA	NA	Yes	75	25	10.0	10.0	0.25	0.25
La Crescenta, Montrose, Glendale, La Canada Flintridge	Crescenta Valley Water District	NA	NA	Yes	40	60	10.0	10.0	0.25	0.25
La Habra	The City of La Habra Water Division	NA	0.5	Yes	NA	NA	10.0	10.0	0.25	0.50
La Habra Heights	La Habra Heights County Water District	ND	ND	Yes	NA	NA	10.0	10.0	0.25	0.25
La Puente	La Puente Valley County Water District	NA	NA	No	0	100	10.0	10.0	0.25	0.25
La Verne	California Water Utilities	ND	NA	Yes	70	30	10.0	10.0	0.25	0.25
Lakewood	City of Lakewood	12	NA	No	0	100	12.0	12.0	0.25	0.25
Las Flores	Las Flores Water Company	NA	NA	Yes	65	35	10.0	10.0	0.25	0.25
Lomita	City of Lomita Water System	NA	NA	Yes	100	0	10.0	10.0	0.25	0.25
Long Beach	Long Beach Water Department	NA	NA	Yes	42	58	10.0	10.0	0.25	0.25

APPENDIX C
Manganese and TCE Concentrations In Public Water Supply Within 20-Mile Radius of City of Maywood

City/Community	Purveyor	2009 CCR					Calculated Conc. Based On % of Source Used			
		Groundwater		MWD Water Used	MWD Water %	Ground-water %	Mn		TCE	
		Mn	TCE				Max	Min	Max	Min
		ug/L	ug/L	ug/L	ug/L	ug/L	ug/L	ug/L	ug/L	
Los Angeles	Los Angeles Department of Water and Power	NA	1	Yes	63	12	10.0	10.0	0.28	0.28
Lynwood	California Water Utilities	2.8	NA	Yes	15	85	10.0	10.0	0.25	0.25
Lynwood	Park Water Company	NA	NA	Yes	84	15	10.0	10.0	0.25	0.25
Lynwood Park	Lynwood Park Mutual Water Company	ND	NA	No	0	100	10.0	10.0	0.25	0.25
Manhattan Beach	California Water Utilities	59	NA	Yes	NA	NA	10.0	59.0	0.25	0.25
Maywood	Maywood Mutual Water Company No.1	41.1	NA	Yes	29	71	32.1	32.1	0.25	0.25
Maywood	Maywood Mutual Water Company No.2	63.5	NA	No	0	100	63.5	63.5	0.25	0.25
Maywood	Maywood Mutual Water Company No.3	8.7	2.4	No	0	100	10.0	10.0	2.40	2.40
Monrovia	City of Monrovia Department of Public Works	NA	3.99	No	0	100	10.0	10.0	3.99	3.99
Montebello	California Water Service Company	NA	NA	Yes	NA	NA	10.0	10.0	0.25	0.25
Montebello	Montebello Land and Water Company	ND	NA	No	0	100	10.0	10.0	0.25	0.25
Monterey Park	City of Monterey Park Public Works Water Division	ND	NA	No	0	100	10.0	10.0	0.25	0.25
Norwalk	California Water Utilities	44	0.26	Yes	NA	NA	10.0	44.0	0.25	0.26
Norwalk	Golden State Water Company	NA	NA	Yes	NA	NA	10.0	10.0	0.25	0.25
Orange	City of Orange Water Division	NA	NA	Yes	NA	NA	10.0	10.0	0.25	0.25
Palos Verdes	California Water Utilities	NA	NA	Yes	100	0	10.0	10.0	0.25	0.25
Paramount	California Water Utilities	47.8	NA	Yes	NA	NA	10.0	47.8	0.25	0.25
Pasadena	Pasadena Water & Power	1.8	3.33	Yes	61	36	10.0	10.0	1.35	1.35
Pico Rivera	California Water Utilities	NA	ND	No	0	100	10.0	10.0	0.25	0.25
Pico Rivera	California Water Utilities	1.04	0.5	No	0	100	10.0	10.0	0.50	0.50
Pico Rivera	City of Pico Rivera	NA	ND	No	0	100	10.0	10.0	0.25	0.25
Placentia	Golden State Water Company	NA	NA	Yes	NA	NA	10.0	10.0	0.25	0.25
Pomona	City of Pomona Public Works	NA	2.05	Yes	14	86	10.0	10.0	1.80	1.80
Rancho Dominguez	California Water Service Company	NA	NA	Yes	NA	NA	10.0	10.0	0.25	0.25
Rowland	Rowland Water District	NA	NA	Yes	100	0	10.0	10.0	0.25	0.25
San Dimas	Golden State Water Company	NA	NA	Yes	NA	NA	10.0	10.0	0.25	0.25
San Gabriel	Golden State Water Company	NA	NA	No	0	100	10.0	10.0	0.25	0.25
San Gabriel	San Gabriel County Water Company	NA	NA	No	0	100	10.0	10.0	0.25	0.25
San Marino	California American Water	NA	0.70	Yes	8	92	10.0	10.0	0.66	0.66

APPENDIX C

Manganese and TCE Concentrations In Public Water Supply Within 20-Mile Radius of City of Maywood

City/Community	Purveyor	2009 CCR					Calculated Conc. Based On % of Source Used			
		Groundwater		MWD Water Used	MWD Water %	Ground-water %	Mn		TCE	
		Mn	TCE				Max	Min	Max	Min
		ug/L	ug/L	ug/L	ug/L	ug/L	ug/L	ug/L	ug/L	
Santa Ana	City of Santa Public Works Agency	NA	NA	Yes	31	69	10.0	10.0	0.25	0.25
Santa Monica	City of Santa Monica Water Division	5	0.7	Yes	15	85	10.0	10.0	0.63	0.63
Seal Beach	City of Seal Beach Water Department	NA	NA	Yes	NA	NA	10.0	10.0	0.25	0.25
Sierra Madre	City of Sierra Madre	NA	<0.5	Yes	NA	NA	10.0	10.0	0.25	0.25
Signal Hill	California Water Utilities	ND	NA	Yes	NA	NA	10.0	10.0	0.25	0.25
South Arcadia	Golden State Water Company	NA	ND	No	0	100	10.0	10.0	0.25	0.25
South Gate	California Water Utilities	NA	0.79	No	0	100	10.0	10.0	0.79	0.79
South Gate	City of South Gate Water Division	40	1.17	No	0	100	40.0	40.0	1.17	1.17
South Montebello	South Montebello Irrigation District	No Data	No Data	No	0	100	10.0	10.0	0.25	0.25
South Pasadena	City of South Pasadena	NA	0.9	Yes	NA	NA	10.0	10.0	0.25	0.90
Sunny Slope	Sunny Slope Water Company	NA	NA	No	0	100	10.0	10.0	0.25	0.25
Torrance	City of Torrance	ND	NA	Yes	89	11	10.0	10.0	0.25	0.25
Valencia Heights	Valencia Heights Water Company	NA	NA	Yes	NA	NA	10.0	10.0	0.25	0.25
Valley View	Valley View Mutual Water Company	NA	NA	No	0	100	10.0	10.0	0.25	0.25
Vernon	City of Vernon	61	NA	Yes	NA	NA	10.0	61.0	0.25	0.25
Walnut Park	Walnut Park Mutual Water Company	NA	NA	No	0	100	10.0	10.0	0.25	0.25
Walnut, Cudhay, Huntington Park	Walnut Valley Water District	NA	NA	Yes	100	0	10.0	10.0	0.25	0.25
Westminster	City of Westminster Water Division	2.6	NA	Yes	17	83	10.0	10.0	0.25	0.25
Whittier	California Domestic Water Company	NA	9.1	No	0	100	10.0	10.0	9.10	9.10
Whittier	City of Whittier	NA	ND	No	0	100	10.0	10.0	0.25	0.25
Whittier, La Habra heights, La Mirada, Buena Park	Suburban Water Systems	NA	0.5	Yes	NA	NA	10.0	10.0	0.25	0.50
Whittier, La Marada	California Water Utilities	ND	ND	Yes	NA	NA	10.0	10.0	0.25	0.25
Willowbrook	Golden State Water Company	NA	NA	Yes	NA	NA	10.0	10.0	0.25	0.25
Averages							11.8	15.5	0.45	0.48
							13.7		0.47	

Notes:

2009 CCR - Data as reported in 2009 Consumer Confidence Reports from CDPH

Additional data were obtained from various city websites and Water Replenishment District of Southern California. The Mn and TCE values are reported as average values in the 2009 CCRs.

Mn - Manganese

MWD - Metropolitan Water District; imported surface water.

NA - not available; not detected above the laboratory reporting limit.

ND - not detected above reporting limit; reporting limit not provided.

TCE - trichloroethene

ug/L - micrograms per liter; equivalent to parts per billion

For calculation purposes, results reported as ND or NA are assumed to have a half of the laboratory reporting limit,

e.g., a value of 10 ug/L is used for ND(20). Assume reporting limits of 20 ug/L for Mn and 0.5 ug/L for TCE.

Values less than the detection limit reported in the CCR may be due to using "0" for ND values. For calculation purposes we have assumed that the lowest concentration is half of the detection limit.

APPENDIX D

CHEMICAL OXIDATION REACTION VESSELS AND PRESSURE FILTER SCHEMATICS

FILTRONICS

Filtronics, Inc. • 4000 Leaverton Court
Anaheim, CA 92807 (714) 630-5040 FAX (714) 630-1160
Website: www.filtronics.com Email: info@filtronics.com

FILTRONICS IRON, MANGANESE AND ARSENIC REMOVAL SYSTEMS

Filtronics, Inc., is a manufacturer of down flow pressure sand filters, to use general terms. It does not, however, employ sand or any silica products in its product line. This unique filtration system incorporates the latest technology for the removal of arsenic, iron, manganese, and hydrogen sulfide. The systems utilize a permanent, back washable media, chemical feed system, and oxidation system to accomplish arsenic removals to less than 5 ug/l (ppb). Filtronics **Electromedia**[®] permanent filtering media is capable of filter rates up to 15 gpm per square foot – with the same or better performance than other systems that filter at 3 – 5 gpm per square foot.

Filtronics full-scale arsenic removal units have been in operation since 1992 and our process has been featured in The American Water Works Association *Opflow* publication, Vol 22 No.2 "Question of the Month" as well as in the March 2001 edition of *WaterWorld*. Filtronics **Electromedia**[®] I systems have been shown to reduce arsenic concentrations of 69 to 100 ug/l down to 2.6 ug/l – well below the new 10 ug/l MCL. Recent pilot test results proved a reduction from 39 ug/l to non detectable levels. This data has been validated by third-party laboratory testing. Filtronics systems are designed to be operator friendly and are automated for full, unattended operation. The control panels provide a simple, clear, intuitive display panel for easy operation. The filter, chemical feed systems, well pumps and auxiliary equipment are automatically operated.



Photo 1 – Typical Filtronics filter vessel (behind blue & red piping) and reaction vessels. Note sodium hypochlorite chemical oxidant injection point (foreground right) and backwash reclamation tank (right background).

All **Electromedia**[®] systems have a four-minute backwash duration. Backwash rates are 17 gallons to 20 gallons per minute per square foot, depending upon the media selected. The short duration results in lower wash water requirements and thus provides a better backwash-to-filtration ratio. The high rate and media design provide complete fluidization of the working media. Thorough cleaning of the media is obtained without the requirement of filter cleaning aids such as surface wash and air scour.

TECHNOLOGY DESCRIPTION AND FUNCTION

The process oxidizes soluble iron, manganese, sulfides and arsenic into insoluble forms and uses native iron in the raw water as a coagulant and/or adds an iron coagulant to attract the arsenic. The filter then removes these metals from the water.

OXIDATION: The prime ingredients for chemical reactions, mixing and time, are provided by the dual reaction vessels supplied with the system.

FILTRATION: The filter vessel contains **Electromedia**[®] I, a media specifically designed for iron, manganese and other heavy metal removal. Its adsorptive surface attracts iron and manganese ions and holds them in the bed. The **Electromedia**[®] I system does not require regeneration or media replacement. The system is so effective there is no requirement for "air scouring" or "surface wash" as is needed by other systems. At the end of the filtration cycle the iron, manganese, and arsenic are back-washed from the media and the surfaces are thoroughly scrubbed.

PROCESS ANALYZER: At the discharge of the filter a continuously monitoring analyzer samples the effluent. No calculations or separate analysis is required. This system has a positive response to the oxidant dosage.

OPERATION AND DESIGN SPECIFICATIONS:

- Filter flux rate: 10 gpm/ft² (system available up to 15 gpm/ft²)
- Backwash duration: 4 minutes regardless of loading
- Backwash initiation: 8 to 12 hours, started automatically by a timer with a differential pressure override at 10 psi
- Purge: 1 minute, after each backwash
- Internal distribution system: Hub and lateral/manifold and lateral
- Valving: Pneumatic/butterfly

NOTES:

- CONCRETE 1.**
- 1.1 8K SACK MIX
 - 1.2 AGGREGATE 3/4" - 1" WASHED GRAVEL OR SUITABLE QUARRY STONE.
 - 1.3 WATER TO CEMENT RATIO: 0.35
 - 1.4 USE BOTH WATER AND HIGH RANGE WATER REDUCER.
 - 1.5 POUR CONCRETE WITHIN 2' +/- 1/4" OF LOWER LATERALS.
 - 1.6 WOODEN FLOAT FINISH SATISFACTORY.
- DO NOT USE ANY MIX CONTAINING CHLORIDE. INSURE AGGREGATE IS FREE OF ANY SALT TO PREVENT SPALLING.

- ROUND BAR 2.**
- 2.1 #4 ROUND BAR ON 12" CENTERLINE OR AS APPROVED BY THE CONTRACTOR.
 - 2.2 #4 ROUND BAR WITHIN 6" OF SURFACE.
 - 2.3 RECOMMENDED REBAR SPACING: 6".

- SEALING 3.**
- 3.1 LAY 3/4" DIAMETER ROPE AT PERIMETER OF CONCRETE INSIDE OF VESSEL WHILE CONCRETE IS STILL WET. REMOVE AFTER CONCRETE HAS SET.
 - 3.2 CLEAN DUST AND DEBRIS FROM CHANNEL LEFT BY ROPE. CLEAN VESSEL WALL. INSTALL SUTURE AND WOODEN FLOAT FINISH SATISFACTORY. SEALER SHALL THE RESPECTOR SEALER IS PRODUCT # RC-270 FROM PRODUCT RESEARCH & CHEMICAL.

CONCRETE REQUIREMENTS ARE APPROXIMATE VALUES ONLY. CONCRETE MINIMUM 4500 PSI WITH A FINE AGGREGATE MAX. THIS DRAWING TO BE USED FOR REFERENCE ONLY. FILTRONICS INC. IS NOT RESPONSIBLE FOR CONCRETE OR CONCRETE DESIGN.

CAUTION:

EXTREME CARE SHOULD BE TAKEN WHEN INSTALLING WELDS TO AVOID DAMAGE TO EPOXY LINING OF VESSELS. DO NOT CUT WELDS INSIDE DATA.

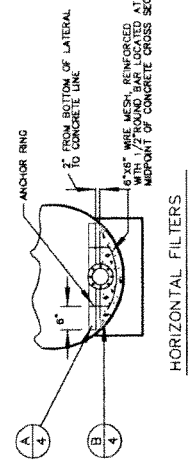
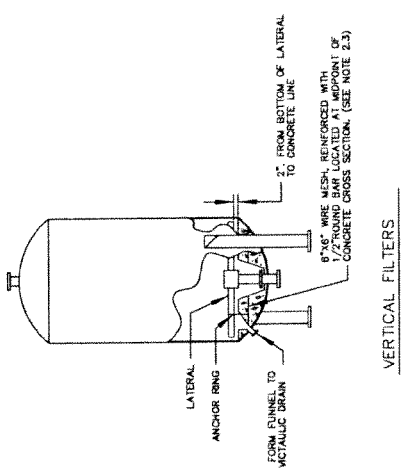

MODEL #	CUBIC YDS. REQ.	ANCHOR RINGS
FV-7	0.4	NO
FV-8	0.5	NO
FV-9	0.8	NO
FV-10	1.1	YES
FH-11	0.8	YES
FH-12	1.0	YES
FH-13	1.6	YES
FH-14	2.2	YES
FH-15	3.3	YES
FH-16	3.9	YES

CONCRETE REQUIREMENTS
ARE APPROXIMATE VALUES ONLY AND FLUCTUATE FROM VESSEL TO VESSEL. (SEE NOTE 1.5)

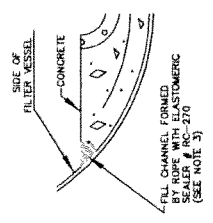

SEALANT INSTALLATION

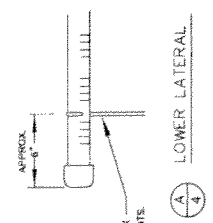
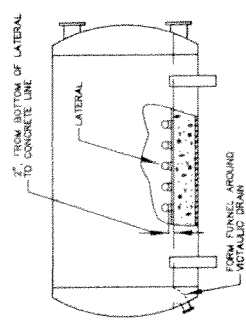
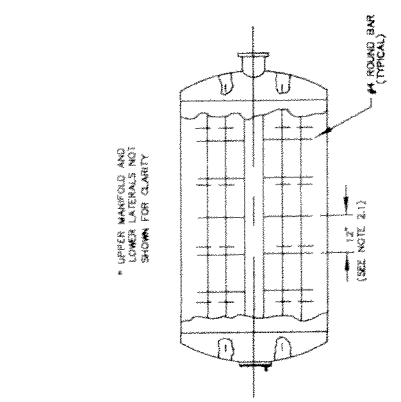

NO.	DATE	REVISION	DESCRIPTION

THIS DOCUMENT IS THE PROPERTY OF FILTRONICS INCORPORATED. IT IS LOANED UPON THE CONDITION THAT THE INFORMATION WILL BE USED ONLY AS SPECIFICALLY AUTHORIZED BY FILTRONICS INCORPORATED AND WILL NOT BE DISCLOSED TO COMPETITIVE SOURCES.

TITLE
ELECTROMEDIA-1 FILTER STATION
CONCRETE INSTALLATION FOR VESSELS

SCALE NONE
DRAWN BY D. W. BARNER
APPROVED BY S-930

DATE 08/09/2008
CHECKED BY W. E. HENDS

FILTRONICS, INCORPORATED
4000 LEAVERTON CT. ANNEARKE, CALIFORNIA
(714) 630-3040

SHEET 1 OF 1
DWG. NO. S-930
REV 1

SIZE SCHEDULE (INCHES)

VESSEL (GPM)	DESIGN FLOW/DIAM./LENGTH CONNECTION & OVERALL DIMENSIONS											
	A	B	C	D	E	F	G	H				
V-45	10-45	18	42	2	2.5	3	24	70	84	19	8	
V-70	45-70	20	52	2.5	3	4	24	60	88	21	8	
V-100	71-100	24	62	3	4	6	24	61	78	25	13	
V-150	101-150	24	72	4	6	8	24	101	78	25	8	
V-200	151-200	30	88	6	8	10	30	102	86	31	8	
V-300	201-300	38	90	8	10	12	30	97	100	37	13-1/2	
V-500	301-500	42	90	8	10	12	36	130	112	43	8	
V-700	501-700	48	98	10	12	14	36	142	124	49	12	
V-1000	701-1000	54	108	10	12	16	36	156	136	55	12	
V-1500	1001-1500	54	132	10	12	18	36	180	138	55	12	
V-2000	1501-2000	60	132	10	12	18	36	180	138	55	12	
H-1000	701-1000	48	128	10	12	14	30	61	140	161	12	
H-1500	1001-1500	54	132	10	12	16	30	67	152	157	12	
H-2000	1501-2000	60	138	10	12	18	30	73	164	158	12	
H-2500	1801-2250	68	152	14	16	20	38	79	176	182	12	
H-3000	2000-3000	72	184	16	18	22	42	88	186	222	24	
H-3500	3500-3800	72	216	16	18	24	48	98	198	258	28	
H-4000	4800-6200	84	216	18	24	28	48	108	212	263	28	

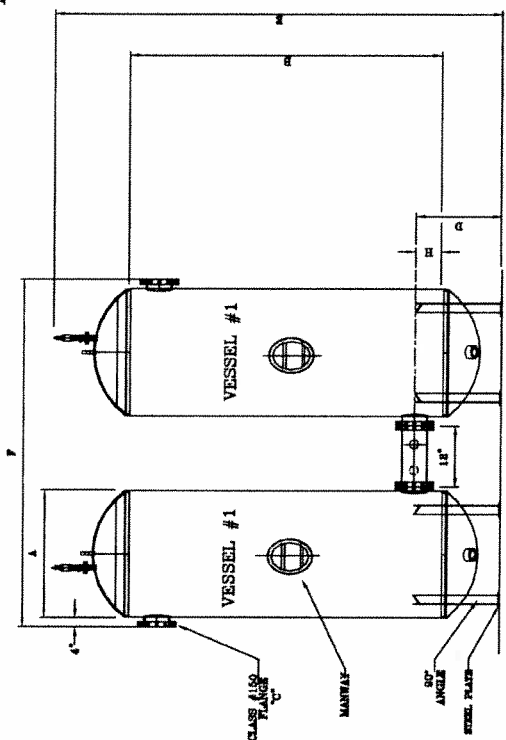
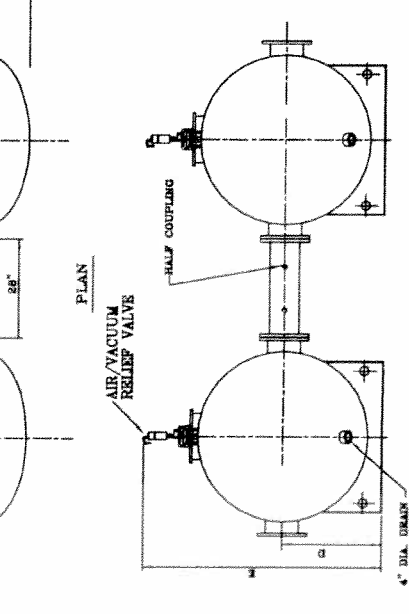
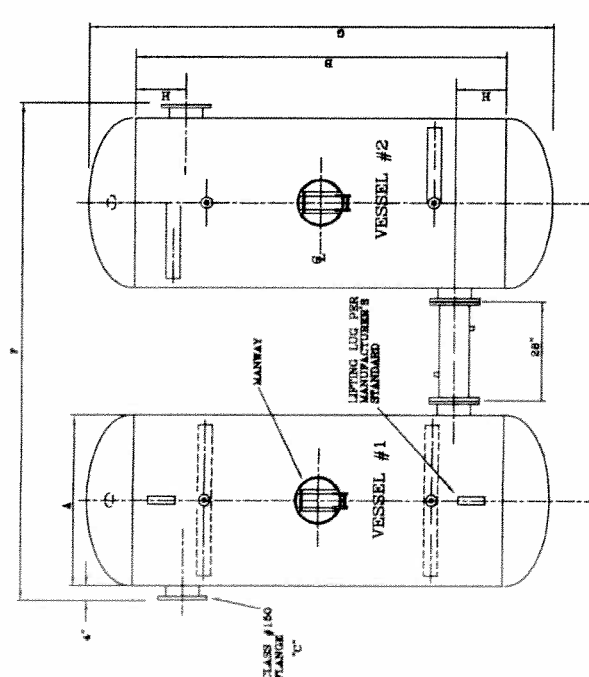
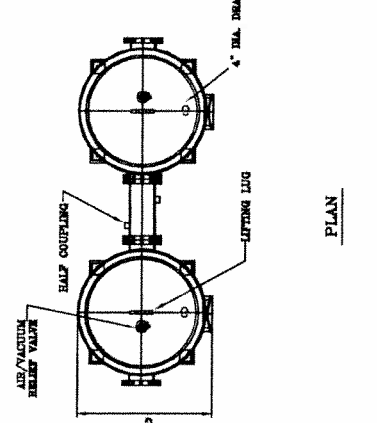

NOTES:

1. ALL DETAILS AND DIMENSIONS INCLUDED HEREON ARE FOR PROJECT PLANNING PURPOSES ONLY AND MUST BE VERIFIED PRIOR TO CONSTRUCTION.
2. TANKS TO BE CONSTRUCTED IN ACCORDANCE WITH THE CODES AND STANDARDS UNLESS OTHERWISE SPECIFIED. VESSEL SHALL BE DESIGNED FOR A WORKING PRESSURE OF 80 PSIG AND HYDROSTATICALLY TESTED FOR 90 PSIG.
3. ALL PIPING 2" DIAMETER AND LARGER SHALL BE FLANGED, CLASS 150.
4. MANWAYS SHALL BE OF A SIZE COMPATIBLE WITH INTERNAL ASSEMBLY PIPING AND VESSEL SIZE.
5. OTHER PIPING CONFIGURATIONS ARE AVAILABLE TO SUIT CUSTOMER REQUIREMENTS. CONSULT MANUFACTURER FOR DIMENSIONS.
6. NOT TO BE USED FOR CONSTRUCTION

HORIZONTAL CONFIGURATION

VERTICAL CONFIGURATION

ELECTROMEDIA-1 FILTER STATION REACTION VESSELS	
DATE	REV
DESIGNED BY	APPROVED BY
CHECKED BY	DATE
PILTRONICS, INCORPORATED	
11111 W. 111th Street, Overland Park, KS 66204	
TEL: (913) 671-1111 FAX: (913) 671-1112	

Q	4-12-2000	GENERAL REVISION	W.L.B.
R	4-12-2000	GENERAL REVISION	P.S.B.
S	11-18-98	GENERAL REVISION	P.S.B.
T	8-18-98	GENERAL REVISION	P.S.B.
U	8-18-98	GENERAL REVISION	P.S.B.
V	8-18-98	GENERAL REVISION	P.S.B.
W	8-18-98	GENERAL REVISION	P.S.B.
X	8-18-98	GENERAL REVISION	P.S.B.
Y	8-18-98	GENERAL REVISION	P.S.B.
Z	8-18-98	GENERAL REVISION	P.S.B.

THIS DOCUMENT IS THE PROPERTY OF PILTRONICS, INCORPORATED. IT IS TO BE USED ONLY AS AUTHORIZED BY THE USER. IT IS NOT TO BE REPRODUCED OR TRANSMITTED IN ANY FORM OR BY ANY MEANS, ELECTRONIC OR MECHANICAL, INCLUDING PHOTOCOPYING, RECORDING, OR BY ANY INFORMATION STORAGE AND RETRIEVAL SYSTEM, WITHOUT THE WRITTEN PERMISSION OF PILTRONICS, INCORPORATED.

S-170D

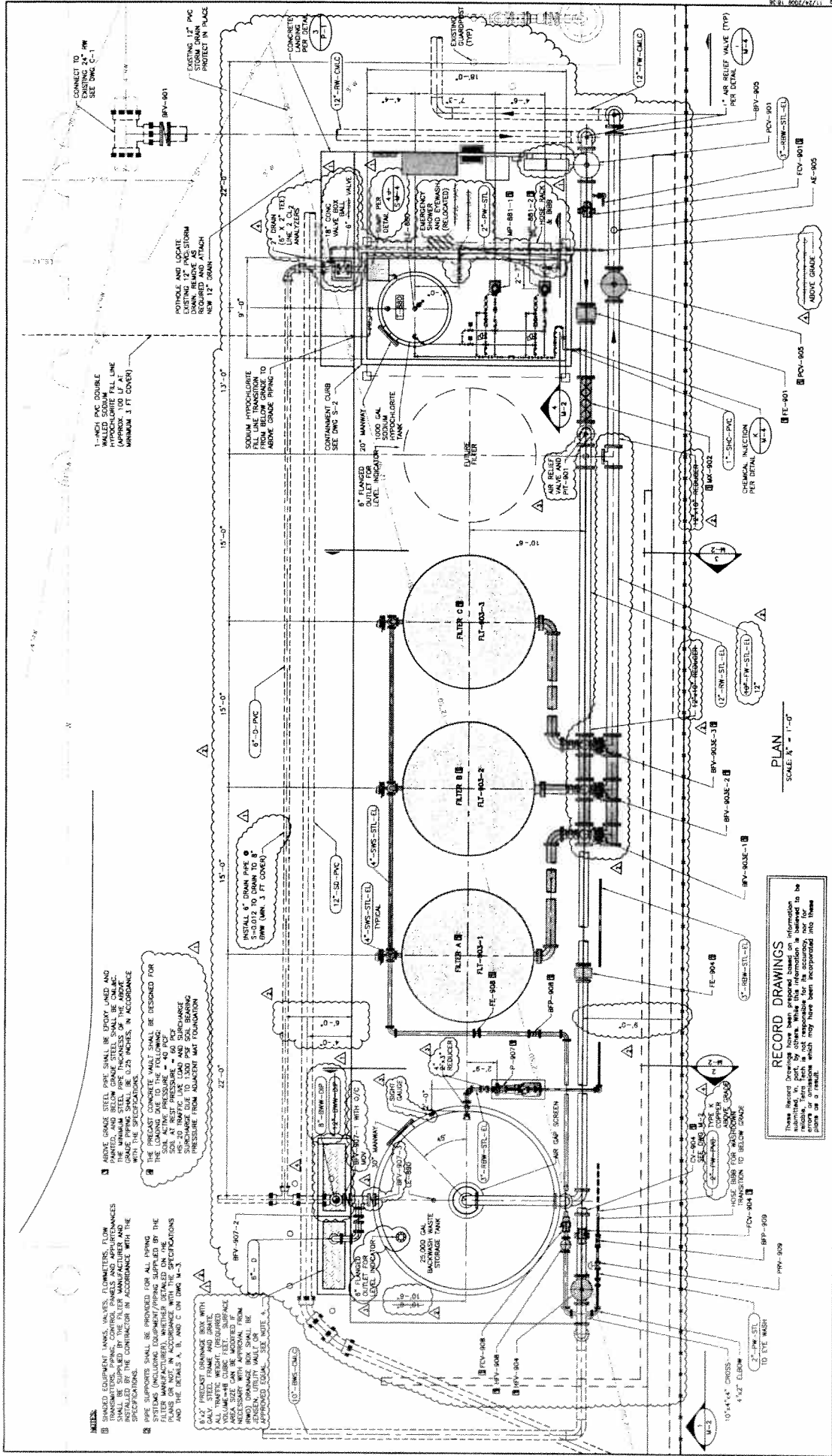

NOTE: 1. ABOVE GRADE STEEL PIPE SHALL BE EPXY LANDED AND PAINTED, AND BELOW GRADE STEEL SHALL BE ON-LAC. GRADE PIPING SHALL BE 0.25 INCHES, IN ACCORDANCE WITH THE SPECIFICATIONS.

2. THE PRECAST CONCRETE VAULT SHALL BE DESIGNED FOR A MINIMUM 150 PSF SURFACE LOAD AND 10 PSF SOIL ACTIVE PRESSURE. A 40 PSF SOIL SURFACE SURCHARGE DUE TO LOADS ON SOIL BEARING PRESSURE FROM ADJACENT MAT FOUNDATION SHALL BE ALLOWED.

3. ABOVE GRADE STEEL PIPE SHALL BE EPXY LANDED AND PAINTED, AND BELOW GRADE STEEL SHALL BE ON-LAC. GRADE PIPING SHALL BE 0.25 INCHES, IN ACCORDANCE WITH THE SPECIFICATIONS.

4. THE PRECAST CONCRETE VAULT SHALL BE DESIGNED FOR A MINIMUM 150 PSF SURFACE LOAD AND 10 PSF SOIL ACTIVE PRESSURE. A 40 PSF SOIL SURFACE SURCHARGE DUE TO LOADS ON SOIL BEARING PRESSURE FROM ADJACENT MAT FOUNDATION SHALL BE ALLOWED.

RECORD DRAWINGS

These Record Drawings have been prepared based on information furnished to the Engineer by the owner. The Engineer is not responsible for the accuracy or completeness of the information furnished to the Engineer, nor for any omissions which may have been incorporated into these drawings.

PLAN
SCALE: 1" = 1'-0"

SCALE	1/4" = 1'-0"
DATE	JUNE 2008
DESIGNED BY	MEMO
CHECKED BY	MEMO
DESIGNED BY NO.	
CHECKED BY NO.	
DATE	10/1/09
DESCRIPTION	
ENGR. DATE	
APPROVED	
REVISIONS	
NO.	DESCRIPTION
1	
2	
3	
4	
5	
6	
7	
8	
9	
10	
11	
12	
13	
14	
15	
16	
17	
18	
19	
20	
21	
22	
23	
24	
25	
26	
27	
28	
29	
30	
31	
32	
33	
34	
35	
36	
37	
38	
39	
40	
41	
42	
43	
44	
45	
46	
47	
48	
49	
50	
51	
52	
53	
54	
55	
56	
57	
58	
59	
60	
61	
62	
63	
64	
65	
66	
67	
68	
69	
70	
71	
72	
73	
74	
75	
76	
77	
78	
79	
80	
81	
82	
83	
84	
85	
86	
87	
88	
89	
90	
91	
92	
93	
94	
95	
96	
97	
98	
99	
100	

TETRA TECH

15665 Lakewood Canyon Road
Suite 200
Folsom, CA 95630
(916) 751-7977
(916) 751-7977 FAX

PLANS PREPARED BY:
STEVEN L. WALLOT

DATE: 10/1/09
SCALE: 1/4" = 1'-0"

IRVINE RANCH WATER DISTRICT
IRVINE DESALTER PROJECT
PR 10376

MANGANESE REMOVAL SYSTEM
MANGANESE REMOVAL FILTERS
PLAN

BOARDS: M-1R1
PROJECT NO.: 00928.0097
SHEET NO.: 11 OF 20